



ROHDE & SCHWARZ

Test and Measurement
Division

Manual

Power Sensor Module

R&S[®] NRP-Z27

DC to 18 GHz / 4 μ W to 400 mW

1169.4102.02

R&S[®] NRP-Z37

DC to 26.5 GHz / 4 μ W to 400 mW

1169.3206.02

Printed in Germany

Dear Customer,

R&S® is a registered trademark of Rohde & Schwarz GmbH & Co. KG.
Trade names are trademarks of the owners.

Operation of the Power Sensor Module R&S NRP-Z27/-Z37 on the R&S NRP base unit

The power sensor module supplied with this manual has firmware version **01.61** or later. To operate it on the R&S NRP base unit, all software components installed on the base unit must have version number **02.00** or later. If you want to use the distortion compensation (command group: SENSE:RGAMma, see page 6-12), the 'Main Program' must have at least version number **3.24**.

The version numbers of the software components can be read out under the menu item 'System Info', in the lines 'Main Program', 'Bootloader' and 'Keybd. Ctrl'. For firmware versions earlier than 02.00, the menu item 'System Info' can be found in the File menu; otherwise, in the System menu.

Tabbed Divider Overview

Data Sheet

Safety Instructions
Certificate of Quality
EU Certificate of Conformity
List of R&S Representatives

Tabbed Divider

- | | |
|----------|---|
| 1 | Chapter 1: Putting into Operation |
| 2 | Chapter 2: Virtual Power Meter |
| 3 | Chapter 3: Operation |
| 4 | Chapter 4: for future extensions |
| 5 | Chapter 5: Remote Control – Basics |
| 6 | Chapter 6: Remote Control – Commands |
| 7 | Chapter 7: for future extensions |
| 8 | Service Instructions |

Technical Information



Power Sensor Modules R&S NRP-Z27, -Z37

For accurate absolute power measurements with the R&S FSMR

The new power sensor modules for the frequency ranges DC to 18 GHz (R&S NRP-Z27) and DC to 26.5 GHz (R&S NRP-Z37) turn the R&S FSMR measuring receivers into precision power meters with a dynamic range as large as -115 dBm to +30 dBm. The sensor modules feature not only all the advantages of the thermal measuring principle, but also reliable and repeatable operation due to the use of a power splitter for signal separation.

Excellent isolation from the receiver input is achieved by means of hardware and by numeric precorrection of the splitter, which yields high total accuracy.

Like all other power sensors of the R&S NRP family, the sensor modules are fully self-contained power meters that are remote-controlled from the R&S FSMR, R&S NRP or any Windows PC via USB.

Power Sensor Modules R&S NRP-Z27, -Z37

Specifications

Bold: Parameter 100% tested.

Italics: Uncertainties calculated from the test assembly specifications and modeled behavior of the sensor.

Normal: Compliance with specifications is ensured by the design or derived from the measurement of related parameters.

Module type		thermoelectric power sensor with RF signal output
Measurand		average power of incident wave
Frequency range		DC to 18 GHz (R&S NRP-Z27) DC to 26.5 GHz (R&S NRP-Z37)
Matching (SWR)	input DC to 2.0 GHz > 2.0 GHz to 4.2 GHz > 4.2 GHz to 8.0 GHz > 8.0 GHz to 12.4 GHz > 12.4 GHz to 18.0 GHz > 18.0 GHz to 26.5 GHz RF signal output DC to 8.0 GHz > 8.0 GHz to 26.5 GHz	R&S NRP-Z27 R&S NRP-Z37 < 1.15 < 1.15 < 1.18 < 1.18 < 1.23 < 1.23 < 1.25 < 1.25 < 1.35 < 1.30 < 1.6 < 1.6 < 2.0 < 2.0
Power measurement range		4 μ W to 400 mW (-24 dBm to +26 dBm) cont., without subranges
Max. power	average pulse energy	0.5 W (+27 dBm) continuous 1.0 W (+30 dBm) for max. 10 minutes 30 W μ s
Display noise ¹⁴⁾		< 240 nW (typ. 120 nW)
Zero offset ¹⁷⁾		< 400 nW (typ. 200 nW)
Zero drift ¹⁸⁾		< 160 nW
Linearity uncertainty ³⁶⁾	input power < 0.1 W > 0.1 W	< 0.02 dB < 0.03 dB
Temperature effect ³⁷⁾	DC to 4.2 GHz > 4.2 GHz to 8.0 GHz > 8.0 GHz to 12.4 GHz > 12.4 GHz to 18.0 GHz > 18.0 GHz to 26.5 GHz	< 0.004 dB/K (typ. 0.0014 dB/K) < 0.005 dB/K (typ. 0.0015 dB/K) < 0.005 dB/K (typ. 0.0017 dB/K) < 0.006 dB/K (typ. 0.0019 dB/K) < 0.009 dB/K (typ. 0.0027 dB/K)
Isolation ³⁸⁾	DC to 2.0 GHz > 2.0 GHz to 12.4 GHz > 12.4 GHz to 18.0 GHz > 18.0 GHz to 26.5 GHz	> 23 (51) dB > 25 (37) dB > 26 (35) dB > 26 (32) dB
Insertion loss between input and RF signal output	DC to 2.0 GHz > 2.0 GHz to 4.2 GHz > 4.2 GHz to 8.0 GHz > 8.0 GHz to 12.4 GHz > 12.4 GHz to 18.0 GHz > 18.0 GHz to 26.5 GHz power coefficient	< 14 dB (typ. 12.5 dB) < 15 dB (typ. 13.5 dB) < 16 dB (typ. 14.0 dB) < 17 dB (typ. 14.5 dB) < 18 dB (typ. 15.5 dB) < 19 dB (typ. 16.5 dB) $\pm (0.02 + 0.002 f / \text{GHz})$ dB/W
RF connectors	input RF signal output	N (male) for R&S NRP-Z27 3.5 mm (male) for R&S NRP-Z37 3.5 mm (male)

Calibration uncertainty ³⁹⁾	DC to < 100 MHz 100 MHz to 4.2 GHz > 4.2 GHz to 8.0 GHz > 8.0 GHz to 12.4 GHz > 12.4 GHz to 18.0 GHz > 18.0 GHz to 26.5 GHz	<i>0.063 dB</i> <i>0.070 dB</i> <i>0.082 dB</i> <i>0.088 dB</i> <i>0.109 dB</i> <i>0.118 dB</i>
Uncertainty for absolute power measurements with matched load (SWR < 1.05) ⁴⁰⁾ From -10 dBm to +26 dBm	DC to < 100 MHz 100 MHz to 4.2 GHz > 4.2 GHz to 8.0 GHz > 8.0 GHz to 12.4 GHz > 12.4 GHz to 18.0 GHz > 18.0 GHz to 26.5 GHz	20°C to 25°C 15°C to 35°C 0°C to 50°C <i>0.070 dB</i> <i>0.077 dB</i> <i>0.103 dB</i> <i>0.075 dB</i> <i>0.082 dB</i> <i>0.106 dB</i> <i>0.087 dB</i> <i>0.094 dB</i> <i>0.119 dB</i> <i>0.093 dB</i> <i>0.101 dB</i> <i>0.130 dB</i> <i>0.112 dB</i> <i>0.121 dB</i> <i>0.151 dB</i> <i>0.122 dB</i> <i>0.137 dB</i> <i>0.190 dB</i>
Uncertainty for absolute power measurements on R&S FSMR26 ⁴⁰⁾ From -10 dBm to +26 dBm	DC to < 100 MHz 100 MHz to 4.2 GHz > 4.2 GHz to 8.0 GHz > 8.0 GHz to 18.0 GHz > 18.0 GHz to 26.5 GHz	20°C to 25°C 15°C to 35°C 0°C to 50°C <i>0.104 dB</i> <i>0.109 dB</i> <i>0.128 dB</i> <i>0.116 dB</i> <i>0.120 dB</i> <i>0.138 dB</i> <i>0.163 dB</i> <i>0.166 dB</i> <i>0.181 dB</i> <i>0.183 dB</i> <i>0.187 dB</i> <i>0.207 dB</i> <i>0.226 dB</i> <i>0.235 dB</i> <i>0.269 dB</i>
After numerical isolation correction	DC to < 100 MHz 100 MHz to 4.2 GHz > 4.2 GHz to 8.0 GHz > 8.0 GHz to 12.4 GHz > 12.4 GHz to 18.0 GHz > 18.0 GHz to 26.5 GHz	<i>0.067 dB</i> <i>0.074 dB</i> <i>0.101 dB</i> <i>0.077 dB</i> <i>0.083 dB</i> <i>0.107 dB</i> <i>0.092 dB</i> <i>0.099 dB</i> <i>0.123 dB</i> <i>0.099 dB</i> <i>0.107 dB</i> <i>0.135 dB</i> <i>0.122 dB</i> <i>0.130 dB</i> <i>0.159 dB</i> <i>0.154 dB</i> <i>0.167 dB</i> <i>0.212 dB</i>
Measurement window ⁷⁾	duration shape	2 × (1 ms to 300 ms) rectangular (integrating behavior) Von Hann (smoothing filter, for efficient suppression of result variations due to modulation ²⁶⁾)
Measurement time ²⁷⁾		N × (duration of measurement window + 0.5 ms) + t _z t _z : < 82 ms
Zeroing (duration)	depends on averaging filter AUTO ON AUTO OFF Integration time ¹⁶⁾ < 4 s 4 s...16 s > 16 s	4 s 4 s integration time ¹⁶⁾ 16 s
Averaging filter	modes normal operating mode ²³⁾ resolution fixed noise operating mode noise content max. measurement time ²⁴⁾ averaging factor N result output moving average repeat	AUTO OFF (fixed averaging factor) AUTO ON (continuously auto-adapted) AUTO ONCE (automatically fixed once) setting of filter depends on power to be measured and resolution 1 (1 dB), 2 (0.1 dB), 3 (0.01 dB), 4 (0.001 dB) filter set to specified noise content 0.0001 dB to 1 dB 0.01 s to 1000 s 1 to 2 ¹⁶ (number of averaged measurement windows) continuous with every newly evaluated measurement window (e.g. in case of manual operation via R&S NRP) only final result (e.g. in case of remote control of R&S NRP)

Duty cycle correction ⁸⁾		0.001 % to 99.999 %
Attenuation correction	function range	correcting the measurement result by means of a fixed factor (dB offset) -100.000 dB to +100.000 dB
Γ correction	function parameters	reducing the influence of mismatched sources ²⁹⁾ magnitude and phase of reflection coefficient of source
Frequency response correction	function parameter	taking into account the calibration factors relevant for the test frequency carrier frequency (center frequency)
Isolation correction	function parameter	taking into account the reflection coefficient of the load on the RF signal output magnitude and phase of reflection coefficient of the load
Interface to host	power supply remote control trigger input	typ. +5 V / 100 mA (USB low-power device) as a USB device (function) in full-speed mode, compatible with USB 1.0/1.1/2.0 specifications differential (0 / +3.3 V)
Dimensions (W × H × L)		48 mm × 50 mm × 250 mm length incl. connecting cable: approx. 1.75 m
Weight		< 0.7 kg

1)

... See the R&S NRP data sheet (PD 0757.7023.21).

35)

36) For relative measurements referenced to 0 dBm.

37) Taking into consideration change of sensitivity for power sensor, drift of insertion loss for power splitter and phase change of RF cable (with the R&S FSMR26 connected to the RF signal output).

38) Between RF signal output and input of the integrated power sensor. It can be expressed by $20 \text{ dB} \log |s_{21} / (s_{23} \cdot s_{31})|$, where

s_{xy} are S parameters of the power splitter (including cable). Port 1 denotes the input of the power sensor module, port 2 the input of the internal power sensor and port 3 the RF signal output. The power measurement error introduced due to mismatch of an R&S FSMR26 does not exceed 0.06 dB from DC to 2 GHz, 0.10 dB up to 18 GHz, and 0.14 dB up to 26.5 GHz.

Values in parentheses represent effective isolation, which can be achieved after numerical isolation correction of the measurement result inside the sensor. Isolation correction requires the complex reflection coefficient of the load on the RF signal output to be sent to the sensor. Residual power measurement error introduced by an R&S FSMR26 after isolation correction does not exceed 0.01 dB from DC to 2 GHz, 0.025 dB up to 8 GHz, 0.04 dB up to 18 GHz, and 0.07 dB up to 26.5 GHz.

39) Expanded uncertainty (k=2) for absolute power measurements at the calibration level (0 dBm) and the calibration frequencies at 20°C to 25°C. Specifications include zero offset and display noise (up to a 2σ value of 0.01 dB). The load on the RF signal output must be a low-reflection type (SWR < 1.05) or isolated by numerical correction (see footnote 38).

Calibration frequencies: 0.1/0.5/1/3/5/10/50/100 MHz; from 100 MHz to the upper frequency limit in increments of 100 MHz.

40) At calibration frequencies. Includes the effects of calibration uncertainty, linearity, zero offset and drift, temperature, display noise (up to a value of 0.01 dB) and mismatch of the load on the RF signal output. For power levels below -10 dBm, the effect of zero offset must be calculated separately.

General specifications

See the R&S NRP data sheet (PD 0757.7023.21), Sensors R&S NRP-Z11/-Z21.

Accessories

See the R&S NRP data sheet (PD 0757.7023.21)

Ordering information

Description	Type	Order No.
Power Sensor Module 4 μ W to 400 mW; DC to 18 GHz	R&S NRP-Z27	1169.4102.02
Power Sensor Module 4 μ W to 400 mW; DC to 26.5 GHz	R&S NRP-Z37	1169.3206.02





Before putting the product into operation for the first time, make sure to read the following



Safety Instructions

Rohde & Schwarz makes every effort to keep the safety standard of its products up to date and to offer its customers the highest possible degree of safety. Our products and the auxiliary equipment required for them are designed and tested in accordance with the relevant safety standards. Compliance with these standards is continuously monitored by our quality assurance system. This product has been designed and tested in accordance with the EC Certificate of Conformity and has left the manufacturer's plant in a condition fully complying with safety standards. To maintain this condition and to ensure safe operation, observe all instructions and warnings provided in this manual. If you have any questions regarding these safety instructions, Rohde & Schwarz will be happy to answer them.

Furthermore, it is your responsibility to use the product in an appropriate manner. This product is designed for use solely in industrial and laboratory environments or in the field and must not be used in any way that may cause personal injury or property damage. You are responsible if the product is used for an intention other than its designated purpose or in disregard of the manufacturer's instructions. The manufacturer shall assume no responsibility for such use of the product.

The product is used for its designated purpose if it is used in accordance with its operating manual and within its performance limits (see data sheet, documentation, the following safety instructions). Using the products requires technical skills and knowledge of English. It is therefore essential that the products be used exclusively by skilled and specialized staff or thoroughly trained personnel with the required skills. If personal safety gear is required for using Rohde & Schwarz products, this will be indicated at the appropriate place in the product documentation.

Symbols and safety labels

Observe operating instructions	Weight indication for units >18 kg	Danger of electric shock	Warning! Hot surface	PE terminal	Ground	Ground terminal	Attention! Electrostatic sensitive devices

Supply voltage ON/OFF	Standby indication	Direct current (DC)	Alternating current (AC)	Direct/alternating current (DC/AC)	Device fully protected by double/reinforced insulation

Safety Instructions

Observing the safety instructions will help prevent personal injury or damage of any kind caused by dangerous situations. Therefore, carefully read through and adhere to the following safety instructions before putting the product into operation. It is also absolutely essential to observe the additional safety instructions on personal safety that appear in other parts of the documentation. In these safety instructions, the word "product" refers to all merchandise sold and distributed by Rohde & Schwarz, including instruments, systems and all accessories.

Tags and their meaning

DANGER	This tag indicates a safety hazard with a high potential of risk for the user that can result in death or serious injuries.
WARNING	This tag indicates a safety hazard with a medium potential of risk for the user that can result in death or serious injuries.
CAUTION	This tag indicates a safety hazard with a low potential of risk for the user that can result in slight or minor injuries.
ATTENTION	This tag indicates the possibility of incorrect use that can cause damage to the product.
NOTE	This tag indicates a situation where the user should pay special attention to operating the product but which does not lead to damage.

These tags are in accordance with the standard definition for civil applications in the European Economic Area. Definitions that deviate from the standard definition may also exist. It is therefore essential to make sure that the tags described here are always used only in connection with the associated documentation and the associated product. The use of tags in connection with unassociated products or unassociated documentation can result in misinterpretations and thus contribute to personal injury or material damage.

Basic safety instructions

1. The product may be operated only under the operating conditions and in the positions specified by the manufacturer. Its ventilation must not be obstructed during operation. Unless otherwise specified, the following requirements apply to Rohde & Schwarz products:
prescribed operating position is always with the housing floor facing down, IP protection 2X, pollution severity 2, overvoltage category 2, use only in enclosed spaces, max. operation altitude max. 2000 m. Unless specified otherwise in the data sheet, a tolerance of $\pm 10\%$ shall apply to the nominal voltage and of $\pm 5\%$ to the nominal frequency.
2. Applicable local or national safety regulations and rules for the prevention of accidents must be observed in all work performed. The product may be opened only by authorized, specially trained personnel. Prior to performing any work on the product or opening the product, the product must be disconnected from the supply network. Any adjustments, replacements of parts, maintenance or repair must be carried out only by technical personnel authorized by Rohde & Schwarz. Only original parts may be used for replacing parts relevant to safety (e.g. power switches, power transformers, fuses). A safety test must always be performed after parts relevant to safety have been replaced (visual inspection, PE conductor test, insulation resistance measurement, leakage current measurement, functional test).
3. As with all industrially manufactured goods, the use of substances that induce an allergic reaction (allergens, e.g. nickel) such as aluminum cannot be generally excluded. If you develop an allergic reaction (such as a skin rash, frequent sneezing, red eyes or respiratory difficulties), consult a physician immediately to determine the cause.

Safety Instructions

4. If products/components are mechanically and/or thermally processed in a manner that goes beyond their intended use, hazardous substances (heavy-metal dust such as lead, beryllium, nickel) may be released. For this reason, the product may only be disassembled, e.g. for disposal purposes, by specially trained personnel. Improper disassembly may be hazardous to your health. National waste disposal regulations must be observed.
5. If handling the product yields hazardous substances or fuels that must be disposed of in a special way, e.g. coolants or engine oils that must be replenished regularly, the safety instructions of the manufacturer of the hazardous substances or fuels and the applicable regional waste disposal regulations must be observed. Also observe the relevant safety instructions in the product documentation.
6. Depending on the function, certain products such as RF radio equipment can produce an elevated level of electromagnetic radiation. Considering that unborn life requires increased protection, pregnant women should be protected by appropriate measures. Persons with pacemakers may also be endangered by electromagnetic radiation. The employer is required to assess workplaces where there is a special risk of exposure to radiation and, if necessary, take measures to avert the danger.
7. Operating the products requires special training and intense concentration. Make certain that persons who use the products are physically, mentally and emotionally fit enough to handle operating the products; otherwise injuries or material damage may occur. It is the responsibility of the employer to select suitable personnel for operating the products.
8. Prior to switching on the product, it must be ensured that the nominal voltage setting on the product matches the nominal voltage of the AC supply network. If a different voltage is to be set, the power fuse of the product may have to be changed accordingly.
9. In the case of products of safety class I with movable power cord and connector, operation is permitted only on sockets with earthing contact and protective earth connection.
10. Intentionally breaking the protective earth connection either in the feed line or in the product itself is not permitted. Doing so can result in the danger of an electric shock from the product. If extension cords or connector strips are implemented, they must be checked on a regular basis to ensure that they are safe to use.
11. If the product has no power switch for disconnection from the AC supply, the plug of the connecting cable is regarded as the disconnecting device. In such cases, it must be ensured that the power plug is easily reachable and accessible at all times (length of connecting cable approx. 2 m). Functional or electronic switches are not suitable for providing disconnection from the AC supply. If products without power switches are integrated in racks or systems, a disconnecting device must be provided at the system level.
12. Never use the product if the power cable is damaged. By taking appropriate safety measures and carefully laying the power cable, ensure that the cable cannot be damaged and that no one can be hurt by e.g. tripping over the cable or suffering an electric shock.
13. The product may be operated only from TN/TT supply networks fused with max. 16 A.
14. Do not insert the plug into sockets that are dusty or dirty. Insert the plug firmly and all the way into the socket. Otherwise this can result in sparks, fire and/or injuries.
15. Do not overload any sockets, extension cords or connector strips; doing so can cause fire or electric shocks.
16. For measurements in circuits with voltages $V_{rms} > 30 V$, suitable measures (e.g. appropriate measuring equipment, fusing, current limiting, electrical separation, insulation) should be taken to avoid any hazards.
17. Ensure that the connections with information technology equipment comply with IEC 950/EN 60950.
18. Never remove the cover or part of the housing while you are operating the product. This will expose circuits and components and can lead to injuries, fire or damage to the product.

Safety Instructions

19. If a product is to be permanently installed, the connection between the PE terminal on site and the product's PE conductor must be made first before any other connection is made. The product may be installed and connected only by a skilled electrician.
20. For permanently installed equipment without built-in fuses, circuit breakers or similar protective devices, the supply circuit must be fused in such a way that suitable protection is provided for users and products.
21. Do not insert any objects into the openings in the housing that are not designed for this purpose. Never pour any liquids onto or into the housing. This can cause short circuits inside the product and/or electric shocks, fire or injuries.
22. Use suitable overvoltage protection to ensure that no overvoltage (such as that caused by a thunderstorm) can reach the product. Otherwise the operating personnel will be endangered by electric shocks.
23. Rohde & Schwarz products are not protected against penetration of water, unless otherwise specified (see also safety instruction 1.). If this is not taken into account, there exists the danger of electric shock or damage to the product, which can also lead to personal injury.
24. Never use the product under conditions in which condensation has formed or can form in or on the product, e.g. if the product was moved from a cold to a warm environment.
25. Do not close any slots or openings on the product, since they are necessary for ventilation and prevent the product from overheating. Do not place the product on soft surfaces such as sofas or rugs or inside a closed housing, unless this is well ventilated.
26. Do not place the product on heat-generating devices such as radiators or fan heaters. The temperature of the environment must not exceed the maximum temperature specified in the data sheet.
27. Batteries and storage batteries must not be exposed to high temperatures or fire. Keep batteries and storage batteries away from children. If batteries or storage batteries are improperly replaced, this can cause an explosion (warning: lithium cells). Replace the battery or storage battery only with the matching Rohde & Schwarz type (see spare parts list). Batteries and storage batteries are hazardous waste. Dispose of them only in specially marked containers. Observe local regulations regarding waste disposal. Do not short-circuit batteries or storage batteries.
28. Please be aware that in the event of a fire, toxic substances (gases, liquids etc.) that may be hazardous to your health may escape from the product.
29. Please be aware of the weight of the product. Be careful when moving it; otherwise you may injure your back or other parts of your body.
30. Do not place the product on surfaces, vehicles, cabinets or tables that for reasons of weight or stability are unsuitable for this purpose. Always follow the manufacturer's installation instructions when installing the product and fastening it to objects or structures (e.g. walls and shelves).
31. Handles on the products are designed exclusively for personnel to hold or carry the product. It is therefore not permissible to use handles for fastening the product to or on means of transport such as cranes, fork lifts, wagons, etc. The user is responsible for securely fastening the products to or on the means of transport and for observing the safety regulations of the manufacturer of the means of transport. Noncompliance can result in personal injury or material damage.
32. If you use the product in a vehicle, it is the sole responsibility of the driver to drive the vehicle safely. Adequately secure the product in the vehicle to prevent injuries or other damage in the event of an accident. Never use the product in a moving vehicle if doing so could distract the driver of the vehicle. The driver is always responsible for the safety of the vehicle; the manufacturer assumes no responsibility for accidents or collisions.
33. If a laser product (e.g. a CD/DVD drive) is integrated in a Rohde & Schwarz product, do not use any other settings or functions than those described in the documentation. Otherwise this may be hazardous to your health, since the laser beam can cause irreversible damage to your eyes. Never try to take such products apart, and never look into the laser beam.



Por favor lea imprescindiblemente antes de la primera puesta en funcionamiento las siguientes informaciones de seguridad



Informaciones de seguridad

Es el principio de Rohde & Schwarz de tener a sus productos siempre al día con los estándares de seguridad y de ofrecer a sus clientes el máximo grado de seguridad. Nuestros productos y todos los equipos adicionales son siempre fabricados y examinados según las normas de seguridad vigentes. Nuestra sección de gestión de la seguridad de calidad controla constantemente que sean cumplidas estas normas. Este producto ha sido fabricado y examinado según el comprobante de conformidad adjunto según las normas de la CE y ha salido de nuestra planta en estado impecable según los estándares técnicos de seguridad. Para poder preservar este estado y garantizar un funcionamiento libre de peligros, deberá el usuario atenerse a todas las informaciones, informaciones de seguridad y notas de alerta. Rohde&Schwarz está siempre a su disposición en caso de que tengan preguntas referentes a estas informaciones de seguridad.

Además queda en la responsabilidad del usuario utilizar el producto en la forma debida. Este producto solamente fue elaborado para ser utilizado en la industria y el laboratorio o para fines de campo y de ninguna manera deberá ser utilizado de modo que alguna persona/cosa pueda ser dañada. El uso del producto fuera de sus fines definidos o despreciando las informaciones de seguridad del fabricante queda en la responsabilidad del usuario. El fabricante no se hace en ninguna forma responsable de consecuencias a causa del maluso del producto.

Se parte del uso correcto del producto para los fines definidos si el producto es utilizado dentro de las instrucciones del correspondiente manual del uso y dentro del margen de rendimiento definido (ver hoja de datos, documentación, informaciones de seguridad que siguen). El uso de los productos hace necesarios conocimientos profundos y el conocimiento del idioma inglés. Por eso se deberá tener en cuenta de exclusivamente autorizar para el uso de los productos a personas peritas o debidamente minuciosamente instruidas con los conocimientos citados. Si fuera necesaria indumentaria de seguridad para el uso de productos de R&S, encontrará la información debida en la documentación del producto en el capítulo correspondiente.

Símbolos y definiciones de seguridad

Ver manual de instrucciones del uso	Informaciones para maquinaria con un peso de > 18kg	Peligro de golpe de corriente	¡Advertencia! Superficie caliente	Conexión a conductor protector	Conexión a tierra	Conexión a masa conductora	¡Cuidado! Elementos de construcción con peligro de carga electrostática

potencia EN MARCHA/PARADA	Indicación Stand-by	Corriente continua DC	Corriente alterna AC	Corriente continua/alterna DC/AC	El aparato está protegido en su totalidad por un aislamiento de doble refuerzo

Informaciones de seguridad

Tener en cuenta las informaciones de seguridad sirve para tratar de evitar daños y peligros de toda clase. Es necesario de que se lean las siguientes informaciones de seguridad concienzudamente y se tengan en cuenta debidamente antes de la puesta en funcionamiento del producto. También deberán ser tenidas en cuenta las informaciones para la protección de personas que encontrarán en otro capítulo de esta documentación y que también son obligatorias de seguir. En las informaciones de seguridad actuales hemos juntado todos los objetos vendidos por Rohde&Schwarz bajo la denominación de „producto“, entre ellos también aparatos, instalaciones así como toda clase de accesorios.

Palabras de señal y su significado

PELIGRO	Indica un punto de peligro con gran potencial de riesgo para el usuario. Punto de peligro que puede llevar hasta la muerte o graves heridas.
ADVERTENCIA	Indica un punto de peligro con un potencial de riesgo mediano para el usuario. Punto de peligro que puede llevar hasta la muerte o graves heridas .
ATENCIÓN	Indica un punto de peligro con un potencial de riesgo pequeño para el usuario. Punto de peligro que puede llevar hasta heridas leves o pequeñas
CUIDADO	Indica la posibilidad de utilizar mal el producto y a consecuencia dañarlo.
INFORMACIÓN	Indica una situación en la que deberían seguirse las instrucciones en el uso del producto, pero que no consecuentemente deben de llevar a un daño del mismo.

Las palabras de señal corresponden a la definición habitual para aplicaciones civiles en el ámbito de la comunidad económica europea. Pueden existir definiciones diferentes a esta definición. Por eso se debiera tener en cuenta que las palabras de señal aquí descritas sean utilizadas siempre solamente en combinación con la correspondiente documentación y solamente en combinación con el producto correspondiente. La utilización de las palabras de señal en combinación con productos o documentaciones que no les correspondan puede llevar a malinterpretaciones y tener por consecuencia daños en personas u objetos.

Informaciones de seguridad elementales

1. El producto solamente debe ser utilizado según lo indicado por el fabricante referente a la situación y posición de funcionamiento sin que se obstruya la ventilación. Si no se convino de otra manera, es para los productos R&S válido lo que sigue: como posición de funcionamiento se define principalmente la posición con el suelo de la caja para abajo , modo de protección IP 2X, grado de suciedad 2, categoría de sobrecarga eléctrica 2, utilizar solamente en estancias interiores, utilización hasta 2000 m sobre el nivel del mar.
A menos que se especifique otra cosa en la hoja de datos, se aplicará una tolerancia de $\pm 10\%$ sobre el voltaje nominal y de $\pm 5\%$ sobre la frecuencia nominal.
2. En todos los trabajos deberán ser tenidas en cuenta las normas locales de seguridad de trabajo y de prevención de accidentes. El producto solamente debe de ser abierto por personal périto autorizado. Antes de efectuar trabajos en el producto o abrirlo deberá este ser desconectado de la corriente. El ajuste, el cambio de partes, la manutención y la reparación deberán ser solamente efectuadas por electricistas autorizados por R&S. Si se reponen partes con importancia para los aspectos de seguridad (por ejemplo el enchufe, los transformadores o los fusibles), solamente podrán ser sustituidos por partes originales. Despues de cada recambio de partes elementales para la seguridad deberá ser efectuado un control de

Informaciones de seguridad

- seguridad (control a primera vista, control de conductor protector, medición de resistencia de aislamiento, medición de medición de la corriente conductora, control de funcionamiento).
3. Como en todo producto de fabricación industrial no puede ser excluido en general de que se produzcan al usarlo elementos que puedan generar alergias, los llamados elementos alergénicos (por ejemplo el níquel). Si se produjeran en el trato con productos R&S reacciones alérgicas, como por ejemplo urticaria, estornudos frecuentes, irritación de la conjuntiva o dificultades al respirar, se deberá consultar inmediatamente a un médico para averiguar los motivos de estas reacciones.
 4. Si productos / elementos de construcción son tratados fuera del funcionamiento definido de forma mecánica o térmica, pueden generarse elementos peligrosos (polvos de sustancia de metales pesados como por ejemplo plomo, berilio, níquel). La partición elemental del producto, como por ejemplo sucede en el tratamiento de materias residuales, debe de ser efectuada solamente por personal especializado para estos tratamientos. La partición elemental efectuada inadecuadamente puede generar daños para la salud. Se deben tener en cuenta las directivas nacionales referentes al tratamiento de materias residuales.
 5. En el caso de que se produjeran agentes de peligro o combustibles en la aplicación del producto que debieran de ser transferidos a un tratamiento de materias residuales, como por ejemplo agentes refrigerantes que deben ser repuestos en periodos definidos, o aceites para motores, deberán ser tenidas en cuenta las prescripciones de seguridad del fabricante de estos agentes de peligro o combustibles y las regulaciones regionales para el tratamiento de materias residuales. Cuiden también de tener en cuenta en caso dado las prescripciones de seguridad especiales en la descripción del producto.
 6. Ciertos productos, como por ejemplo las instalaciones de radiación HF, pueden a causa de su función natural, emitir una radiación electromagnética aumentada. En vista a la protección de la vida en desarrollo deberían ser protegidas personas embarazadas debidamente. También las personas con un bypass pueden correr peligro a causa de la radiación electromagnética. El empresario está comprometido a valorar y señalar áreas de trabajo en las que se corra un riesgo de exposición a radiaciones aumentadas de riesgo aumentado para evitar riesgos.
 7. La utilización de los productos requiere instrucciones especiales y una alta concentración en el manejo. Debe de ponerse por seguro de que las personas que manejen los productos estén a la altura de los requerimientos necesarios referente a sus aptitudes físicas, psíquicas y emocionales, ya que de otra manera no se pueden excluir lesiones o daños de objetos. El empresario lleva la responsabilidad de seleccionar el personal usuario apto para el manejo de los productos.
 8. Antes de la puesta en marcha del producto se deberá tener por seguro de que la tensión preseleccionada en el producto equivalga a la del la red de distribución. Si es necesario cambiar la preselección de la tensión también se deberán en caso dabo cambiar los fusibles correspondientes del producto.
 9. Productos de la clase de seguridad I con alimentación móvil y enchufe individual de producto solamente deberán ser conectados para el funcionamiento a tomas de corriente de contacto de seguridad y con conductor protector conectado.
 10. Queda prohibida toda clase de interrupción intencionada del conductor protector, tanto en la toma de corriente como en el mismo producto ya que puede tener como consecuencia el peligro de golpe de corriente por el producto. Si se utilizaran cables o enchufes de extensión se deberá poner al seguro, que es controlado su estado técnico de seguridad.
 11. Si el producto no está equipado con un interruptor para desconectarlo de la red, se deberá considerar el enchufe del cable de distribución como interruptor. En estos casos deberá asegurar de que el enchufe sea de fácil acceso y nabejo (medida del cable de distribución aproximadamente 2 m). Los interruptores de función o electrónicos no son aptos para el corte de la red eléctrica. Si los productos sin interruptor están integrados en construcciones o instalaciones, se deberá instalar el interruptor al nivel de la instalación.

Informaciones de seguridad

12. No utilice nunca el producto si está dañado el cable eléctrico. Asegure a través de las medidas de protección y de instalación adecuadas de que el cable de eléctrico no pueda ser dañado o de que nadie pueda ser dañado por él, por ejemplo al tropezar o por un golpe de corriente.
13. Solamente está permitido el funcionamiento en redes de distribución TN/TT aseguradas con fusibles de como máximo 16 A.
14. Nunca conecte el enchufe en tomas de corriente sucias o llenas de polvo. Introduzca el enchufe por completo y fuertemente en la toma de corriente. Si no tiene en consideración estas indicaciones se arriesga a que se originen chispas, fuego y/o heridas.
15. No sobrecargue las tomas de corriente, los cables de extensión o los enchufes de extensión ya que esto pudiera causar fuego o golpes de corriente.
16. En las mediciones en circuitos de corriente con una tensión de entrada de $U_{eff} > 30 \text{ V}$ se deberá tomar las precauciones debidas para impedir cualquier peligro (por ejemplo medios de medición adecuados, seguros, limitación de tensión, corte protector, aislamiento etc.).
17. En caso de conexión con aparatos de la técnica informática se deberá tener en cuenta que estos cumplan los requisitos de la EC950/EN60950.
18. Nunca abra la tapa o parte de ella si el producto está en funcionamiento. Esto pone a descubierto los cables y componentes eléctricos y puede causar heridas, fuego o daños en el producto.
19. Si un producto es instalado fijamente en un lugar, se deberá primero conectar el conductor protector fijo con el conductor protector del aparato antes de hacer cualquier otra conexión. La instalación y la conexión deberán ser efectuadas por un electricista especializado.
20. En caso de que los productos que son instalados fijamente en un lugar sean sin protector implementado, autointerruptor o similares objetos de protección, deberá la toma de corriente estar protegida de manera que los productos o los usuarios estén suficientemente protegidos.
21. Por favor, no introduzca ningún objeto que no esté destinado a ello en los orificios de la caja del aparato. No vierta nunca ninguna clase de líquidos sobre o en la caja. Esto puede producir corto circuitos en el producto y/o puede causar golpes de corriente, fuego o heridas.
22. Asegúrese con la protección adecuada de que no pueda originarse en el producto una sobrecarga por ejemplo a causa de una tormenta. Si no se verá el personal que lo utilice expuesto al peligro de un golpe de corriente.
23. Los productos R&S no están protegidos contra el agua si no es que exista otra indicación, ver también punto 1. Si no se tiene en cuenta esto se arriesga el peligro de golpe de corriente o de daños en el producto lo cual también puede llevar al peligro de personas.
24. No utilice el producto bajo condiciones en las que pueda producirse y se hayan producido líquidos de condensación en o dentro del producto como por ejemplo cuando se desplaza el producto de un lugar frío a un lugar caliente.
25. Por favor no cierre ninguna ranura u orificio del producto, ya que estas son necesarias para la ventilación e impiden que el producto se caliente demasiado. No pongan el producto encima de materiales blandos como por ejemplo sofás o alfombras o dentro de una caja cerrada, si esta no está suficientemente ventilada.
26. No ponga el producto sobre aparatos que produzcan calor, como por ejemplo radiadores o calentadores. La temperatura ambiental no debe superar la temperatura máxima especificada en la hoja de datos.

Informaciones de seguridad

27. Baterías y acumuladores no deben de ser expuestos a temperaturas altas o al fuego. Guardar baterías y acumuladores fuera del alcance de los niños. Si las baterías o los acumuladores no son cambiados con la debida atención existirá peligro de explosión (atención celulas de Litio). Cambiar las baterías o los acumuladores solamente por los del tipo R&S correspondiente (ver lista de piezas de recambio). Baterías y acumuladores son deshechos problemáticos. Por favor tirenlos en los recipientes especiales para este fin. Por favor tengan en cuenta las prescripciones nacionales de cada país referente al tratamiento de deshechos. Nunca sometan las baterías o acumuladores a un corto circuito.
28. Tengan en consideración de que en caso de un incendio pueden escaparse gases tóxicos del producto, que pueden causar daños a la salud.
29. Por favor tengan en cuenta que en caso de un incendio pueden desprenderse del producto agentes venenosos (gases, líquidos etc.) que pueden generar daños a la salud.
30. No sitúe el producto encima de superficies, vehículos, estantes o mesas, que por sus características de peso o de estabilidad no sean aptas para él. Siga siempre las instrucciones de instalación del fabricante cuando instale y asegure el producto en objetos o estructuras (por ejemplo paredes y estantes).
31. Las asas instaladas en los productos sirven solamente de ayuda para el manejo que solamente está previsto para personas. Por eso no está permitido utilizar las asas para la sujecion en o sobre medios de transporte como por ejemplo grúas, carretillas elevadoras de horquilla, carros etc. El usuario es responsable de que los productos sean sujetados de forma segura a los medios de transporte y de que las prescripciones de seguridad del fabricante de los medios de transporte sean tenidas en cuenta. En caso de que no se tengan en cuenta pueden causarse daños en personas y objetos.
32. Si llega a utilizar el producto dentro de un vehículo, queda en la responsabilidad absoluta del conductor que conducir el vehículo de manera segura. Asegure el producto dentro del vehículo debidamente para evitar en caso de un accidente las lesiones u otra clase de daños. No utilice nunca el producto dentro de un vehículo en movimiento si esto pudiera distraer al conductor. Siempre queda en la responsabilidad absoluta del conductor la seguridad del vehículo y el fabricante no asumirá ninguna clase de responsabilidad por accidentes o colisiones.
33. Dado el caso de que esté integrado un producto de laser en un producto R&S (por ejemplo CD/DVD-ROM) no utilice otras instalaciones o funciones que las descritas en la documentación. De otra manera pondrá en peligro su salud, ya que el rayo laser puede dañar irreversiblemente sus ojos. Nunca trate de descomponer estos productos. Nunca mire dentro del rayo laser.

Certified Quality System

DIN EN ISO 9001 : 2000
DIN EN 9100 : 2003
DIN EN ISO 14001 : 1996

DQS REG. NO 001954 QM/ST UM

QUALITÄTSZERTIFIKAT

Sehr geehrter Kunde,

Sie haben sich für den Kauf eines Rohde & Schwarz-Produktes entschieden. Hiermit erhalten Sie ein nach modernsten Fertigungsmethoden hergestelltes Produkt. Es wurde nach den Regeln unseres Managementsystems entwickelt, gefertigt und geprüft.

Das Rohde & Schwarz Managementsystem ist zertifiziert nach:

DIN EN ISO 9001:2000
DIN EN 9100:2003
DIN EN ISO 14001:1996

CERTIFICATE OF QUALITY

Dear Customer,

you have decided to buy a Rohde & Schwarz product. You are thus assured of receiving a product that is manufactured using the most modern methods available. This product was developed, manufactured and tested in compliance with our quality management system standards.

The Rohde & Schwarz quality management system is certified according to:

DIN EN ISO 9001:2000
DIN EN 9100:2003
DIN EN ISO 14001:1996

CERTIFICAT DE QUALITÉ

Cher Client,

vous avez choisi d'acheter un produit Rohde & Schwarz. Vous disposez donc d'un produit fabriqué d'après les méthodes les plus avancées. Le développement, la fabrication et les tests respectent nos normes de gestion qualité.

Le système de gestion qualité de Rohde & Schwarz a été homologué conformément aux normes:

DIN EN ISO 9001:2000
DIN EN 9100:2003
DIN EN ISO 14001:1996



ROHDE & SCHWARZ



Certificate No.: 2002-36, page 1

This is to certify that:

Equipment type	Stock No.	Designation
NRP	1143.8500.02	Power Meter
NRP-B1	1146.9008.02	Sensor Check Source
NRP-B2	1146.8801.02	Second Sensor Input
NRP-B3	1146.8501.02	Battery Supply
NRP-B4	1146.9308.02	Ethernet Lan-Interface
NRP-B5	1146.9608.02	3rd und 4th Sensor
NRP-B6	1146.9908.02	Rear-Panel Sensor

complies with the provisions of the Directive of the Council of the European Union on the approximation of the laws of the Member States

- relating to electrical equipment for use within defined voltage limits (73/23/EEC revised by 93/68/EEC)
- relating to electromagnetic compatibility (89/336/EEC revised by 91/263/EEC, 92/31/EEC, 93/68/EEC)

Conformity is proven by compliance with the following standards:

EN61010-1 : 2001-12
EN55011 : 1998 + A1 : 1999
EN61326 : 1997 + A1 : 1998 + A2 : 2001

For the assessment of electromagnetic compatibility, the limits of radio interference for Class B equipment as well as the immunity to interference for operation in industry have been used as a basis.

Affixing the EC conformity mark as from 2002

ROHDE & SCHWARZ GmbH & Co. KG
Mühldorfstr. 15, D-81671 München

Munich, 2005-10-28

Central Quality Management FS-QZ / Radde



Certificate No.: 2002-36, page 2

This is to certify that:

Equipment type	Stock No.	Designation
NRP-Z3	1146.7005.02	USB Adapter
NRP-Z4	1146.8001.02/.04	USB Adapter
NRP-Z11	1138.3004.02/.04	Average Power Sensor
NRP-Z21	1137.6000.02	Average Power Sensor
NRP-Z22	1137.7506.02	Average Power Sensor
NRP-Z23	1137.8002.02	Average Power Sensor
NRP-Z24	1137.8502.02	Average Power Sensor
NRP-Z27	1169.4102.02	Power Sensor Module
NRP-Z37	1169.3206.02	Power Sensor Module
NRP-Z51	1138.0005.02	Thermal Power Sensor
NRP-Z55	1138.2008.02	Thermal Power Sensor
NRP-Z91	1168.8004.02/.04	Average Power Sensor

complies with the provisions of the Directive of the Council of the European Union on the approximation of the laws of the Member States

- relating to electrical equipment for use within defined voltage limits (73/23/EEC revised by 93/68/EEC)
- relating to electromagnetic compatibility (89/336/EEC revised by 91/263/EEC, 92/31/EEC, 93/68/EEC)

Conformity is proven by compliance with the following standards:

EN61010-1 : 2001-12
EN55011 : 1998 + A1 : 1999
EN61326 : 1997 + A1 : 1998 + A2 : 2001

For the assessment of electromagnetic compatibility, the limits of radio interference for Class B equipment as well as the immunity to interference for operation in industry have been used as a basis.

Affixing the EC conformity mark as from 2002

ROHDE & SCHWARZ GmbH & Co. KG
Mühldorfstr. 15, D-81671 München

Munich, 2005-10-28

Central Quality Management FS-QZ / Radde

Customer Support

Technical support – where and when you need it

For quick, expert help with any Rohde & Schwarz equipment, contact one of our Customer Support Centers. A team of highly qualified engineers provides telephone support and will work with you to find a solution to your query on any aspect of the operation, programming or applications of Rohde & Schwarz equipment.

Up-to-date information and upgrades

To keep your Rohde & Schwarz equipment always up-to-date, please subscribe to an electronic newsletter at

<http://www.rohde-schwarz.com/www/response.nsf/newsletterpreselection>

or request the desired information and upgrades via email from your Customer Support Center (addresses see below).

Feedback

We want to know if we are meeting your support needs. If you have any comments please email us and let us know CustomerSupport.Feedback@rohde-schwarz.com.

USA & Canada

Monday to Friday (except US-state holidays)
8:00 AM – 8:00 PM Eastern Standard Time (EST)

USA: 888-test-rsa (888-837-8772) (opt 2)
From outside USA: +1 410 910 7800 (opt 2)
Fax: 410 910 7801

E-Mail: Customer.Support@rsa.rohde-schwarz.com

Rest of World

Monday to Friday (except German-state holidays)
08:00 – 17:00 Central European Time (CET)

Europe: +49 (0) 180 512 42 42
From outside Europe: +49 89 4129 13776
Fax: +49 (0) 89 41 29 637 78

E-Mail: CustomerSupport@rohde-schwarz.com



ROHDE & SCHWARZ

Adressen/Addresses

FIRMENSITZ/HEADQUARTERS

(Tel) Phone
(Fax) Fax
E-mail

Rohde & Schwarz GmbH & Co. KG
Mühlendorfstraße 15 · D-81671 München
Postfach 80 14 69 · D-81614 München

(Tel) +49 (89) 41 29-0
(Fax) +49 89 4129-121 64
info@rohde-schwarz.com

WERKE/PLANTS

Rohde & Schwarz Messgerätebau GmbH
Riedbachstraße 58 · D-87700 Memmingen
Postfach 1652 · D-87686 Memmingen

(Tel) +49 (8331) 108-0
(Fax) +49 (8331) 108-11 24
info.rsdmb@rohde-schwarz.com

Rohde & Schwarz GmbH & Co. KG
Werk Teisnach
Kaikenrieder Straße 27 · D-94244 Teisnach
Postfach 1149 · D-94240 Teisnach

(Tel) +49 (9923) 857-0
(Fax) +49 (9923) 857-11 74
info.rsdts@rohde-schwarz.com

Rohde & Schwarz GmbH & Co. KG
Dienstleistungszentrum Köln
Graf-Zeppelin-Straße 18 · D-51147 Köln
Postfach 98 02 60 · D-51130 Köln

(Tel) +49 (2203) 49-0
(Fax) +49 (2203) 49 51-229
info.rsd@rohde-schwarz.com
schwarz.com-service.rsd@rohde-schwarz.com

TOCHTERUNTERNEHMEN/SUBSIDIARIES

Rohde & Schwarz Vertriebs-GmbH
Mühlendorfstraße 15 · D-81671 München
Postfach 80 14 69 · D-81614 München

(Tel) +49 (89) 41 29-137 74
(Fax) +49 (89) 41 29-137 77
customersupport@rohde-schwarz.com

Rohde & Schwarz International GmbH
Mühlendorfstraße 15 · D-81671 München
Postfach 80 14 60 · D-81614 München

(Tel) +49 (89) 41 29-129 84
(Fax) +49 (89) 41 29-120 50
info.rusis@rohde-schwarz.com

Rohde & Schwarz Engineering and Sales GmbH
Mühlendorfstraße 15 · D-81671 München
Postfach 80 14 29 · D-81614 München

(Tel) +49 (89) 41 29-137 11
(Fax) +49 (89) 41 29-137 23
info.rse@rohde-schwarz.com

R&S BICK Mobilfunk GmbH
Fritz-Hahne-Str. 7 · D-31848 Bad Münder
Postfach 2062 · D-31844 Bad Münder

(Tel) +49 (5042) 998-0
(Fax) +49 (5042) 998-105
info.rsbeck@rohde-schwarz.com

Rohde & Schwarz FTK GmbH
Wendenschlossstraße 168, Haus 28
D-12557 Berlin

(Tel) +49 (30) 658 91-122
(Fax) +49 (30) 655 50-221
info.ftk@rohde-schwarz.com

Rohde & Schwarz SIT GmbH
Agastraße 3
D-12489 Berlin

(Tel) +49 (30) 658 84-0
(Fax) +49 (30) 658 84-183
info.sit@rohde-schwarz.com

R&S Systems GmbH
Graf-Zeppelin-Straße 18 · D-51147 Köln
Postfach 98 02 60 · D-51130 Köln

(Tel) +49 (2203) 49-5 23 25
(Fax) +49 (2203) 49-5 23 36
info.rssys@rohde-schwarz.com

ADRESSEN WELTWEIT/ADDRESSES WORLDWIDE

Albania siehe/see Austria

Algeria Rohde & Schwarz
Bureau d'Alger
5B Place de Laperrine
16035 Hydra-Alger

(Tel) +213 (21) 48 20 18
(Fax) +213 (21) 69 46 08

Antilles (Neth.) siehe / see Mexico

Argentina Precision Electronica S.R.L.
Av. Pde Julio A. Roca 710 - 6° Piso
1067 Buenos Aires

(Tel) +541 (14) 331 10 67
(Fax) +541 (14) 334 51 11
alberto.lombardi@prec-elec.com.ar

Australia Rohde & Schwarz (Australia) Pty. Ltd.
Sales Support
Unit 6
2-8 South Street
Rydalmere, N.S.W. 2116

(Tel) +61 (2) 88 45 41 00
(Fax) +61 (2) 96 38 39 88
sales@rsa.us.rohde-schwarz.com

Austria Rohde & Schwarz-Österreich Ges.m.b.H.
Am Europlatz 3
Gebäude B
1120 Wien

(Tel) +43 (1) 602 61 41-0
(Fax) +43 (1) 602 61 41-14
rs-austria@rsoe.rohde-schwarz.com

Azerbaijan Rohde & Schwarz Azerbaijan
Liaison Office Baku
ISR Plaza, 5th floor
340 Nizami Str.
370000 Baku

(Tel) +994 (12) 93 31 38
(Fax) +994 (12) 93 03 14
rs-azerbaijan@rsd.rohde-schwarz.com

Bangladesh BIL Consortium Ltd.
Corporate Office
House-33, Road-4, Block-F
Banani, Dhaka-1213

(Tel) +880 (2) 881 06 53
(Fax) +880 (2) 882 82 91

Barbados siehe / see Mexico

Belarus siehe/see Ukraine

Belgium Rohde & Schwarz Belgium N.V.
Excelsiorlaan 31 Bus 1
1930 Zaventem

(Tel) +32 (2) 721 50 02
(Fax) +32 (2) 725 09 36
info@rsb.rohde-schwarz.com

Belize siehe / see Mexico

Bermuda siehe/see Mexico

Bosnia-Herzegovina siehe/see Slovenia

Brazil Rohde & Schwarz Do Brasil Ltda.
Av. Alfredo Egidio de Souza Aranha (Rod. Araxá)
1° andar - Santo Amaro
04726-170 Sao Paulo - SP

(Tel) +55 (11) 56 44 86 11
(Fax) +55 (11) 56 44 86 25 (sales)
(Fax) +55 (11) 56 44 86 36
sales-brazil@rsdb.rohde-schwarz.com

Brunei George Keen Lee Equipment Pte Ltd.
#11-01 BP Tower
396 Alexandra Road
Singapore 119954

(Tel) +656 276 06 26
(Fax) +656 276 06 29
gkleqpt@singnet.com.sg

Bulgaria Rohde & Schwarz
Representation Office Bulgaria
39, Fridtjof Nansen Blvd.
1000 Sofia

(Tel) +359 (2) 96 343 34
(Fax) +359 (2) 963 21 97
rs-bulgaria@rsbg.rohde-schwarz

Canada Rohde & Schwarz Canada Inc.
555 March Rd.
Kanata, Ontario K2K 2M5

(Tel) +1 (613) 592 80 00
(Fax) +1 (613) 592 80 09
sales@rscanada.ca

Chile Dymeq Ltda.
Av. Larrain 6666
Santiago

(Tel) +56 (2) 339 20 00
(Fax) +56 (2) 339 20 10
dymeq@dymeq.com

China Rohde & Schwarz China Ltd.
Representative Office Beijing
6F, Parkview Center
2 Jiangtai Road
Chao Yang District
Beijing 100016

(Tel) +86 (10) 64 31 28 28
(Fax) +86 (10) 64 37 98 88
info.rschina@rsbp.rohde-schwarz.com

Rohde & Schwarz China Ltd.
Representative Office Shanghai
Room 807-809, Central Plaza
227 Huangpi North Road
Shanghai 200003

(Tel) +86 (21) 63 75 00 18
(Fax) +86 (21) 63 75 91 70
May.Zhu@rsbp.rohde-schwarz.com

Rohde & Schwarz China Ltd.
Representative Office Guangzhou
Room 2903, Metro Plaza
183 Tian He North Road
Guangzhou 510075

(Tel) +86 (20) 87 55 47 58
(Fax) +86 (20) 87 55 47 59
Winnie.Lin@rsbp.rohde-schwarz.com

Adressen/Addresses

India	Rohde & Schwarz India Pvt. Ltd. Mumbai Office B-603, Remi Bizcourt, Shah Industrial Estate, Off Veera Desai Road Andheri West Mumbai - 400 058	(Tel) +91 (22) 26 30 18 10 (Fax) +91 (22) 26 73 20 81 rsindiam@rsnl.net	Kazakhstan	Rohde & Schwarz Kazakhstan Representative Office Almaty Pl. Respubliki 15 480013 Almaty	(Tel) +7 (32) 72 67 23 54 (Fax) +7 (32) 72 67 23 46 rs-kazakhstan@rsd-rohde-schwarz.com
Indonesia	PT Rohde & Schwarz Indonesia Graha Paramita 5th Floor Jln. Denpasar Raya Blok D-2 Jakarta 12940	(Tel) +62 (21) 252 36 08 (Fax) +62 (21) 252 36 07 sales@rsbj.rohde-schwarz.com-services@rsbj.rohde-schwarz.com	Kenya	Excel Enterprises Ltd Dunga Road P.O.Box 42 788 Nairobi	(Tel) +254 (2) 55 80 88 (Fax) +254 (2) 54 46 79
Iran	Rohde & Schwarz Iran Liaison Office Tehran Groundfloor No. 1, 14th Street Khaled Eslamboli (Vozara) Ave. 15117 Tehran	(Tel) +98 (21) 872 42 96 (Fax) +98 (21) 871 90 12 alfred.korff@rsd.rohde-schwarz.com	Korea	Rohde & Schwarz Korea Ltd. 83-29 Nonhyun-Dong, Kangnam-Ku Seoul 135-010	(Tel) +82 (2) 34 85 19 00 (Fax) +82 (2) 547 43 00 sales@rskor.rohde-schwarz.com-service@rskor.rohde-schwarz.com
Ireland	siehe/see United Kingdom		Kuwait	Group Five Trading & Contracting Co. Mezzanine Floor Al-Bana Towers Ahmad Al Jaber Street Sharq	(Tel) +965 (244) 91 72/73/74 (Fax) +965 (244) 95 28 jk_agarwal@yahoo.com
Israel	Eastronics Ltd. Measurement Products 11 Rozanis St. P.O.Box 39300 Tel Aviv 61392	(Tel) +972 (3) 645 87 77 (Fax) +972 (3) 645 86 66 david_hasky@easx.co.il	Latvia	Rohde & Schwarz Danmark A/S Latvian Branch Office Merkela iela 21-301 1050 Riga	(Tel) +371 (7) 50 23 55 (Fax) +371 (7) 50 23 60 latvia@rsdk.rohde-schwarz.com
	J.M. Moss (Engineering) Ltd. Communications Products 9 Oded Street P.O.Box 967 52109 Ramat Gan	(Tel) +972 (3) 631 20 57 (Fax) +972 (3) 631 40 58 jmoss@zahav.net.il	Lebanon	Rohde & Schwarz Liaison Office Riyadh P.O.Box 361 Riyadh 11411	(Tel) +966 (1) 465 64 28 Ext. 303 (Fax) +966 (1) 465 64 28 Ext. 229 chris.porzky@rsd.rohde-schwarz.com
Italy	Rohde & Schwarz Italia S.p.a. Centro Direzionale Lombardo Via Roma 108 20060 Cassina de Pecchi (MI)	(Tel) +39 (02) 95 70 41 (Fax) +39 (02) 95 30 27 72 rsi.info@rsi.rohde-schwarz.com		Netcom P.O.Box 55199 Op. Ex-Presidential Palace Horch Tabet Beirut	(Tel) +961 (1) 48 69 99 (Fax) +961 (1) 49 05 11 tohme.sayar@netcomm.tv
	Rohde & Schwarz Italia S.p.a. Via Tiburtina 1182 00156 Roma	(Tel) +39 (06) 41 59 81 (Fax) +39 (06) 41 59 82 70 rsi.info@rsi.rohde-schwarz.com	Liechtenstein	siehe/see Switzerland	
Jamaica	siehe / see Mexico		Lithuania	Rohde & Schwarz Danmark A/S Lithuanian Branch Office Lukiskiu 5-228 2600 Vilnius	(Tel) +370 (5) 239 50 10 (Fax) +370 (5) 239 50 11 lithuania@rsdk.rohde-schwarz.com
Japan	Rohde & Schwarz Japan K.K. Tokyo Office 711 Bldg., Room 501 (5th floor) 7-11-18 Nishi-Shinjuku Shinjuku-ku Tokyo 160-0023	(Tel) +81 (3) 59 25 12 88 (Fax) +81 (3) 59 25 12 90 scj.support@rsjp.rohde-schwarz.com	Luxembourg	siehe/see Belgium	
	Rohde & Schwarz Japan K.K. Shin-Yokohama Office KM Daiichi Bldg., 8F 2-13-13 Kouhoku-ku Yokohama-shi Kanagawa 222-0033	(Tel) +81 (4) 54 77 35 70	Macedonia	NETRA Sarski odred 7 1000 Skopje	(Tel) +389 (2) 329 82 30 (Fax) +389 (2) 317 74 88 netra@netra.com.sk
	Rohde & Schwarz Japan K.K. Osaka Office TEK Dai 2 Bldg., 8F 1-13-20 Esaka-shi Suita-shi Osaka-fu 564-0063	(Tel) +81 (6) 63 10 96 51	Malaysia	Rohde & Schwarz Malaysia Sdn Bhd Suite 10.04, Level 10, Wisma E&C No. 2 Lorong Dungun Kiri Damansara Heights 50490 Kuala-Lumpur	(Tel) +60 (3) 20 94 00 33 (Fax) +60 (3) 20 94 24 33 sales.malaysia@rohde-schwarz.com
Jordan	Jordan Crown Engineering & Trading Co. Jabal Amman, Second Circle Youssef Ezzideen Street P.O.Box 830414 Amman, 11183	(Tel) +962 (6) 462 17 29 (Fax) +962 (6) 465 96 72 jocrown@go.com.jo	Malta	Tektraco International Technology Ltd. 121, B'Kara Road San Gwann SGN 08	(Tel) +356 (21) 37 43 00 or 37 80 88 (Fax) +356 (21) 37 66 67 sales@tektraco.com
			Mexico	Rohde & Schwarz de Mexico S. de R.L. de C.V. German Centre Oficina 4-2-2 Av. Santa Fé 170 Col. Lomas de Santa Fé 01210 Mexico D.F.	(Tel) +52 (55) 85 03 99 13 (Fax) +52 (55) 85 03 99 16 latinoamerica@rsd-rohde-schwarz.com
			Moldava	siehe/see Austria	
			Nepal	ICTC Pvt. Ltd. Hattisar, Post Box No. 660 Kathmandu	(Tel) +977 (1) 443 48 95 (Fax) +977 (1) 443 49 37 ictc@mos.com.np

Adressen/Addresses

Netherlands	Rohde & Schwarz Nederland B.V. Perkinsbaan 1 3439 ND Nieuwegein	(Tel) +31 (30) 600 17 00 (Fax) +31 (30) 600 17 99 info@rsn.rohde-schwarz.com	Saudi Arabia	Gentec Haji Abdullah Alireza & Co. Ltd. P.O.Box 43054 Riyadh	(Tel) +966 (1) 293 20 35 (Fax) +966 (1) 466 16 57 akanbar@gentec.com.sa
New Zealand	Nichecom 1 Lincoln Ave. Tawa, Wellington	(Tel) +64 (4) 232 32 33 (Fax) +64 (4) 232 32 30 rob@nichecom.co.nz	Serbia-Montenegro	Rohde & Schwarz Representative Office Belgrade Tose Jovanovica 7 11030 Beograd	(Tel) +381 (11) 305 50 25 (Fax) +381 (11) 305 50 24 rs-scg@rscs.rohde-schwarz.com
Nicaragua	siehe/see Mexico				
Nigeria	Ferrostaal Abuja Plot 3323, Barada Close P.O.Box 8513, Wuse Off Amazon Street Maitama, Abuja	(Tel) +234 (9) 413 52 51 (Fax) +234 (9) 413 52 50 fsabuja@rosecom.net	Singapore	Rohde & Schwarz Regional Headquarters Singapore Pte. Ltd. 1 Kaki Bukit View #05-01/02 Techview Singapore 415 941	(Tel) +65 68 46 18 72 (Fax) +65 68 46 12 52
Norway	Rohde & Schwarz Norge AS Enebakkeveien 302 B 1188 Oslo	(Tel) +47 (23) 38 66 00 (Fax) +47 (23) 38 66 01 firmapost@rsnor.rohde-schwarz.com		Rohde & Schwarz Systems & Communications Asia Pte Ltd Service 1 Kaki Bukit View #04-01/07 Techview Singapore 415 941	(Tel) +65 68 46 37 10 (Fax) +65 68 46 00 29 info@rssg.rohde-schwarz.com
Oman	Mustafa Sultan Science & Industry Co.LLC. Test & Measurement Products Way No. 3503 Building No. 241 Postal Code 112 Al Khuwair, Muscat	(Tel) +968 63 60 00 (Fax) +968 60 70 66 m-aziz@mustafasultan.com	Slovak Republic	Specialne systémy a software, a.s. Svrčia ul. 3 841 04 Bratislava 4	(Tel) +421 (2) 65 42 24 88 (Fax) +421 (2) 65 42 07 68 3s@special.sk
Pakistan	Siemens Pakistan 23, West Jinnah Avenue Islamabad	(Tel) +92 (51) 227 22 00 (Fax) +92 (51) 227 54 98 reza.bokhary@siemens.com.pk	Slovenia	Rohde & Schwarz Representative Office Ljubljana Tbilisjska 89 1000 Ljubljana	(Tel) +386 (1) 423 46 51 (Fax) +386 (1) 423 46 11 rs-slovenia@rssi.rohde-schwarz.com
Panama	siehe/see Mexico				
Papua New Guinea	siehe/see Australia				
Paraguay	siehe/see Argentina				
Philippines	Rohde & Schwarz (Philippines) Inc. Unit 2301, PBCOM Tower 6795, Ayala Ave. cor. Herrera St. Makati City	(Tel) +63 (2) 753 14 44 (Fax) +63 (2) 753 14 56	South Africa	Protea Data Systems (Pty.) Ltd. Communications and Measurement Division Private Bag X19 Bramley 2018	(Tel) +27 (11) 719 57 00 (Fax) +27 (11) 786 58 91 unicm@protea.co.za
Poland	Rohde & Schwarz SP.z o.o. Przedstawicielstwo w Polsce ul. Stawki 2, Pietro 28 00-193 Warszawa	(Tel) +48 (22) 860 64 94 (Fax) +48 (22) 860 64 99 rs-poland@rspl.rohde-schwarz.com		Protea Data Systems (Pty.) Ltd. Cape Town Branch Unit G9, Centurion Business Park Bosmandam Road Milnerton Cape Town, 7441	(Tel) +27 (21) 555 36 32 (Fax) +27 (21) 555 42 67 unicm@protea.co.za
Portugal	Rohde & Schwarz Portugal, Lda. Alameda Antonio Sergio 7-R/C - Sala A 2795-023 Linda-a-Velha	(Tel) +351 (21) 415 57 00 (Fax) +351 (21) 415 57 10 info@rspt.rohde-schwarz.com	Spain	Rohde & Schwarz Espana S.A. Salcedo, 11 28034 Madrid	(Tel) +34 (91) 334 10 70 (Fax) +34 (91) 729 05 06 rses@rses.rohde-schwarz.com
Republic Dominican	siehe/see Mexico				
Romania	Rohde & Schwarz Representation Office Bucharest 89 Eroii Sanitari Blvd., sector 5 050472 Bucuresti	(Tel) +40 (21) 411 20 13 (Fax) +40 (21) 410 68 46 rs-romania@rsro.rohde-schwarz.com	Sri Lanka	Dynatel Communications (PTE) Ltd. 451/A Kandy Road Kelaniya	(Tel) +94 (112) 90 80 01 (Fax) +94 (112) 91 04 69 69 dynatel@dyanet.lk
Russian Federation	Rohde & Schwarz International GmbH 119180, Yakimanskaya nab., 2 Moscow	(Tel) +7 (095) 745 88 50 to 53 (Fax) +7 (095) 745 88 54 rs-russia@rsru.rohde-schwarz.com	Sudan	SolarMan Co. Ltd. P.O.Box 11 545 North of Fraouq Cementry 6/7/9 Bldg. 16 Karthoum	(Tel) +249 (183) 47 31 08 (Fax) +249 (183) 47 31 38 solarman29@hotmail.com
Saudi Arabia	Rohde & Schwarz International GmbH - Liaison Office Riyadh c/o Haji Abdullah Alireza Co. Ltd. P.O.Box 361 Riyadh 11411	(Tel) +966 (1) 293 2035 (Fax) +966 (1) 466 1657 chris.porzky@rsd.rohde-schwarz.com	Sweden	Rohde & Schwarz Sverige AB Flygfältsgatan 15 128 30 Skarpnäck	(Tel) +46 (8) 605 19 00 (Fax) +46 (8) 605 19 80 info@rss.rohde-schwarz.com
			Switzerland	Roschi Rohde & Schwarz AG Mühlestr. 7 3063 Ittigen	(Tel) +41 (31) 922 15 22 (Fax) +41 (31) 921 81 01 support@roschi.rohde-schwarz.com
			Syria	Electro Scientific Office Baghdad Street Dawara Clinical Lab. Bldg P.O.Box 8162 Damascus	(Tel) +963 (11) 231 59 74 (Fax) +963 (11) 231 88 75 memo@hamshointl.com

Adressen/Addresses

Taiwan	Rohde & Schwarz Taiwan (Pvt.) Ltd. Floor 14, No. 13, Sec. 2, Pei-Tou Road Taipei 112	(Tel) +886 (2) 28 93 10 88 (Fax) +886 (2) 28 91 72 60 celine.tu@rstw.rohde-schwarz.com	United Kingdom	Rohde & Schwarz UK Ltd. 3000 Manchester Business Park Aviator Way Manchester M22 5TG	(Tel) +44 (870) 735 16 42 (Fax) +44 (1252) 81 14 77 sales@rsuk.rohde-schwarz.com
Tanzania	SSTL Group P.O. Box 7512 Dunga Street Plot 343/345 Dar Es Salaam	(Tel) +255 (22) 276 00 37 (Fax) +255 (22) 276 02 93 sstl@ud.co.tz	Uruguay	Aeromarine S.A. Cerro Largo 1497 11200 Montevideo	(Tel) +598 (2) 400 39 62 (Fax) +598 (2) 401 85 97 cs@aeromarine.com.uy
Thailand	Rohde & Schwarz International Thailand 2nd floor Gems Tower Bangrak, Suriyawong Bangkok 10600	(Tel) +66 (2) 200 07 29 (Fax) +66 (2) 267 00 79	USA	Rohde & Schwarz, Inc. Eastern Regional Office (US Headquarters) 8661A Robert Fulton Drive Columbia, MD 21046-2265	(Tel) +1 (410) 910 78 00 (Fax) +1 (410) 910 78 01 info@rsa.rohde-schwarz.com
	Schmidt Electronics (Thailand) Ltd. Messtechnik 202 Le Concorede Tower, 23rd Fl. Ratchadaphisek Rd. Huay kwang Bangkok 10320	(Tel) +66 (2) 69 41 47 05 (Fax) +66 (2) 69 41 47 06 salestm@schmidtelectronics.com		Rohde & Schwarz, Inc. Central Regional Office / Systems & EMI Products 8080 Tristar Drive Suite 120 Irving, TX 75063	(Tel) +1 (469) 713 53 00 (Fax) +1 (469) 713 53 01 info@rsa.rohde-schwarz.com
	TPP Operation Co. Ltd. Kommunikationstechnik 41/5 Mooban Tarinee Boromrajchonnee Road Talingchan Bangkok 10170	(Tel) +66 (2) 880 93 47 (Fax) +66 (2) 880 93 47		Rohde & Schwarz, Inc. R&D and Application Support 8905 SW Nimbus Ave Suite 240 Beaverton, OR 97008	(Tel) +1 (503) 403 47 00 (Fax) +1 (503) 403 47 01 info@rsa.rohde-schwarz.com
Trinidad & Tobago	siehe/see Mexico	(Tel) (Fax)		Rohde & Schwarz, Inc. Western Regional Office 7700 Irvine Center Drive Suite 100 Irvine, CA 92618	(Tel) +1 (949) 885 70 00 (Fax) +1 (949) 885 70 01 info@rsa.rohde-schwarz.com
Tunisia	Teletek 71, Rue Alain Savary Residence Alain Savary (C64) Cit� el Khadra 1003 Tunis	(Tel) +216 (71) 77 33 88 (Fax) +216 (71) 77 05 53 teletek@gnet.tn		Rohde & Schwarz, Inc. Service & Calibration Center 8661A Robert Fulton Drive Columbia, MD 21046-2265	(Tel) +1 (410) 910 50 02 (Fax) +1 (410) 910 79 31 service.rsa@rsa.rohde-schwarz.com
Turkey	Rohde & Schwarz International GmbH Liaison Office Istanbul Bagdat Cad. 191/3, Arda Apt. B-Blok 81030 Selamicesme-Istanbul	(Tel) +90 (216) 385 19 17 (Fax) +90 (216) 385 19 18 nadir.guerelman@rsd.rohde-schwarz.com	Vietnam	Rohde & Schwarz Representative Office Vietnam Unit 807, 8/F, Schmidt Tower 239 Xuan Thuy Road Cau Giay District Hanoi	(Tel) +84 (4) 834 20 46
Ukraine	Rohde & Schwarz Representative Office Kiev 4, Patris Loumoumba ul. 01042 Kiev	(Tel) +38 (044) 268 60 55 (Fax) +38 (044) 268 83 64 rsbkiev@public.ua.net	West Indies	siehe/see Mexico	
United Arab Emirates	Rohde & Schwarz International GmbH Liaison Office Middle East Vertrieb P.O. Box 31156 Abu Dhabi	(Tel) +971 (2) 6335 670 (Fax) +971 (2) 6335 671 Dario Barisoni@rsd.rohde-schwarz.com			
	Rohde & Schwarz Bick Mobile Communication P.O.Box 17466 JAFZ, PPU ZG-07 Dubai	(Tel) +971 (4) 883 71 35 (Fax) +971 (4) 883 71 36			
	Rohde & Schwarz Emirates L.L.C. ESNAAD Premisses at Mussafah, P.O.Box 31156 Abu Dhabi	(Tel) +971 (2) 55 49 411 (Fax) +971 (2) 55 49 433 rsuaeam@emirates.net.ae			
United Kingdom	Rohde & Schwarz UK Ltd. Ancells Business Park Fleet Hampshire GU51 2UZ	(Tel) +44 (1252) 81 88 88 (sales)+44 (1252) 81 88 18 (service) (Fax) +44 (1252) 81 14 47 sales@rsuk.rohde-schwarz.com			

Table of Contents

1	Putting into Operation	1.1
	Unpacking the sensor	1.1
	Connecting the sensor	1.1
	Operation with the Measuring Receiver R&S FSMR	1.4
	Connecting the power sensor module to the R&S FSMR	1.4
	Connecting the power sensor module to the DUT	1.4
	Performing measurements	1.4
	Operation with the Power Meter R&S NRP	1.5
	Connecting the power sensor module	1.5
	Connecting the power sensor module to the DUT	1.5
	Performing measurements	1.5
	PC control	1.6
	Hardware and software requirements	1.6
	Operation via the Active USB Adapter R&S NRP-Z3	1.7
	Operation via the Passive USB Adapter R&S NRP-Z4	1.8
	Connecting the sensor to the DUT	1.8
	Performing measurements	1.8

Figs.

Fig. 1-1	Configuration with the R&S FSMR	1.4
Fig. 1-2	Configuration with the R&S NRP	1.5
Fig. 1-3	Configuration with Active USB Adapter R&S NRP-Z3.....	1.7
Fig. 1-4	Changing the primary adapter	1.7
Fig. 1-5	Configuration with Passive USB Adapter R&S NRP-Z4	1.8

1 Putting into Operation



Follow the instructions below precisely to prevent damage to the sensor – particularly when you are putting the power sensor module into operation for the first time.

Unpacking the sensor

Remove the power sensor module from its packing and check that nothing is missing. Inspect all items for damage. If you discover any damage, inform the carrier responsible immediately and keep the packing to support any claims for compensation.

It is also best to use the original packing if the power sensor module is to be shipped or transported at a later date.



The power sensor module contains components which can be destroyed by electrostatic discharges. To prevent this happening, never touch the inner conductor of the RF connector and never open the power sensor module.

Connecting the sensor



To prevent EMI, the power sensor module must never be operated with its enclosure wholly or partially removed. Only use shielded cables that meet the relevant EMC standards.

Never exceed the maximum RF power limit. Even brief overloads can destroy the integrated power sensor.

To prevent erroneous measurements, always terminate the RF output of the power sensor module (at the cable end) with a matched load or matched measuring instrument input.

In many cases, the RF connector only requires manual tightening. However, for maximal measurement accuracy, the RF connector must be tightened using a torque wrench with a nominal torque of 1.36 Nm (12" lbs.) for the N connector of the R&S NRP-Z27, or 0.9 Nm (8" lbs.) for the 3.5 mm connector of both power sensor modules.

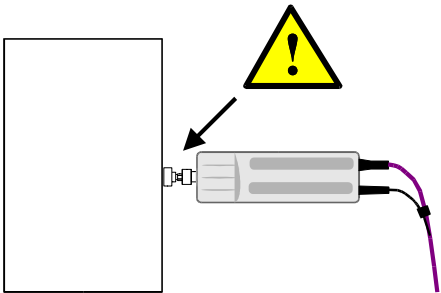

Do not apply excessive mechanical force to the RF connectors of the R&S NRP-Z27/-Z37 and DUT!

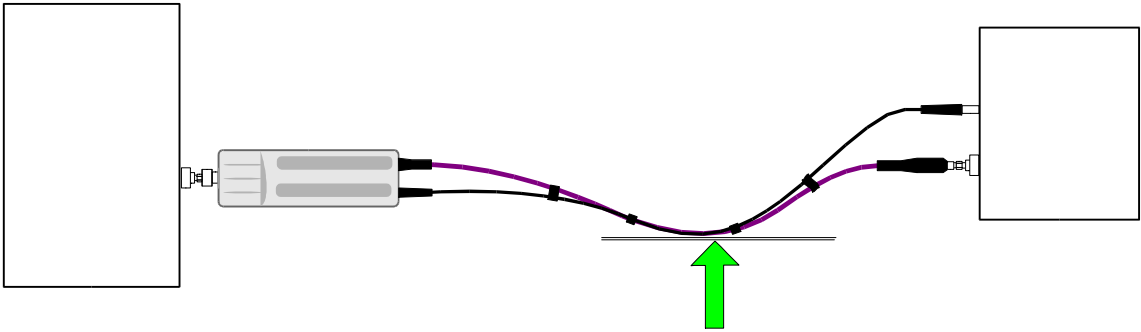
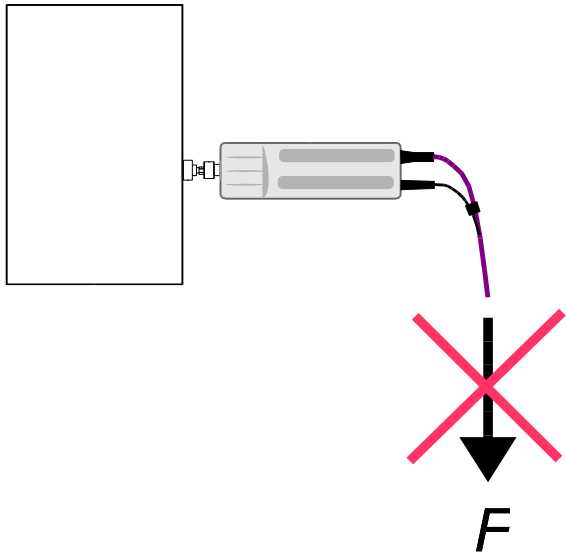
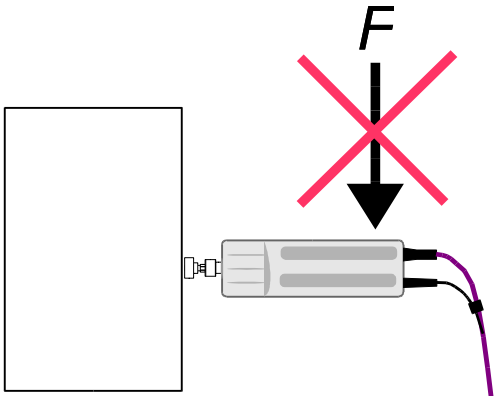

Make sure the bending radius of the RF connecting cable is at least 75 mm!

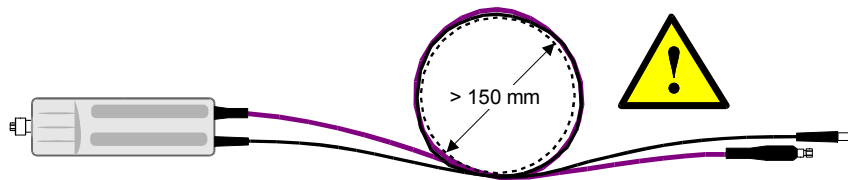

A tighter bend can permanently impair the measuring accuracy of the power measurement module!

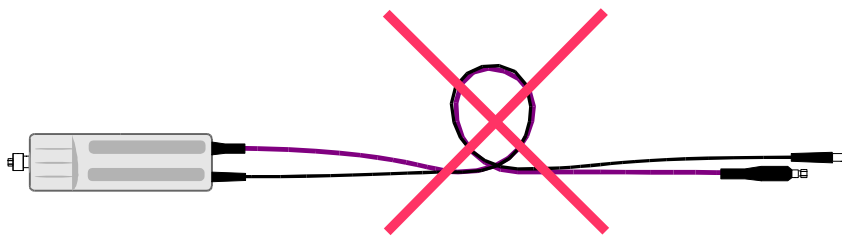

Operation with the Measuring Receiver R&S FSMR

Connecting the power sensor module to the R&S FSMR

The power sensor module can be connected to the Measuring Receiver R&S FSMR when it is in operation. The multiple circular plug-in connector must be inserted, red marking upwards, into the *POWER SENSOR* connector. Then connect the 3.5 mm male connector of the RF cable with measurement input *RF INPUT 50 Ω*. If you are using model R&S FSMR26 or R&S FSMR50, you must first install the appropriate test port adapter with 3.5 mm female connector (R&S 1021.0512.00). With model R&S FSMR3, which has a built-in N-connector, screw on the adapter with the 3.5 mm female connector and male N connector that is supplied. Only the use of these adapters ensures correct functioning of the *VSWR Correction* function on the R&S FSMR.

Connecting the power sensor module to the DUT

The power sensor modules have a male N connector (R&S NRP-Z27) or a male 3.5 mm connector (R&S NRP-Z37) on their RF input and can thus be connected to any standard female N or 2.92 mm/3.5 mm/SMA connector, respectively. To connect the power sensor module to the DUT more easily and without tilting it, relieve it by slightly lifting it.

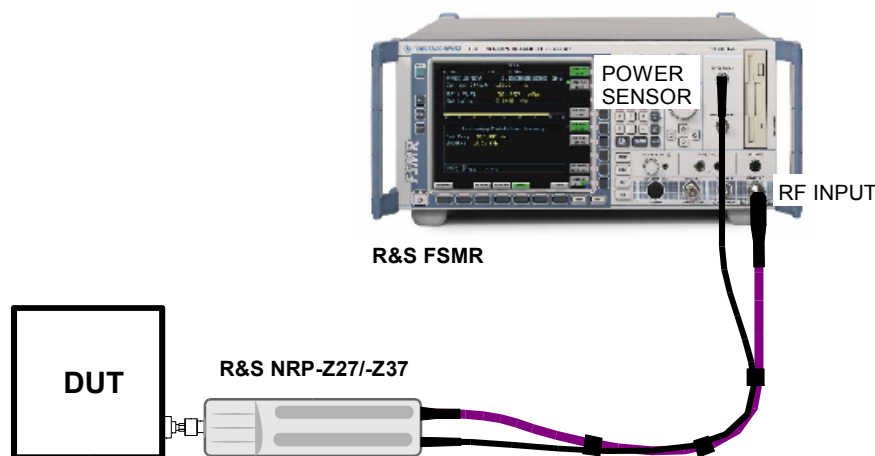

Fig. 1-1 Configuration with the R&S FSMR

Performing measurements

The R&S FSMR handles the power sensors modules in a manner similar to the sensors of the R&S NRP-Z series. To call up the power meter functionality, first press the PRESET key and then the PWR METER softkey. For further details on operation, refer to the operating manual for the R&S FSMR.

Operation with the Power Meter R&S NRP

Connecting the power sensor module

The power sensor module can be connected to the R&S NRP base unit when it is in operation. The multiple circular plug-in connector must be inserted, red marking upwards, into one of the R&S NRP base unit's sensor connectors. When the power sensor module is connected, it is detected by the R&S NRP base unit and initialized.

Terminate the output of the RF cable with a 3.5 mm precision termination (with female connector input). The exact matching value is insignificant as long as the standing wave ratio of the measurement frequency remains smaller than 1.05. Otherwise, you have to check whether the increased measurement uncertainty can be accepted (see the *Isolation* parameter in the specifications as well as *SENse:RGAMma* group of commands in chapter 6).

Connecting the power sensor module to the DUT

The power sensor modules have a male N connector (R&S NRP-Z27) or a male 3.5 mm connector (R&S NRP-Z37) on their RF input and can thus be connected to any standard female N or 2.92 mm/3.5 mm/SMA connector, respectively. To connect the power sensor module to the DUT more easily and without tilting it, relieve it by slightly lifting it.

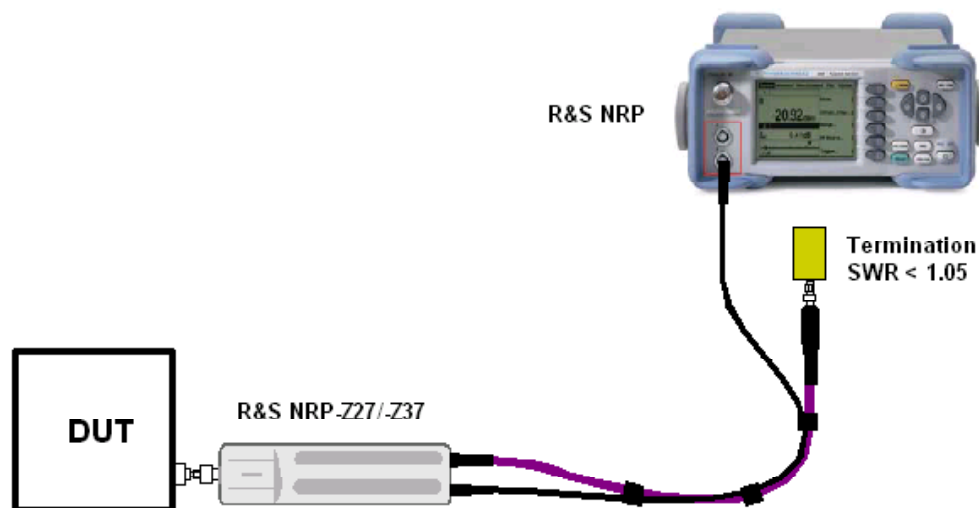

Fig. 1-2 Configuration with the R&S NRP

Performing measurements

The R&S NRP handles the power sensor modules in the same manner as the thermal power sensors of the R&S NRP-Z5x series. An exception is the S-parameter correction function, which is always activated in the power sensor modules. This function takes the integrated power splitter into consideration. Therefore, the influence of adapters or attenuators which are connected ahead of the input of the power sensor module cannot be compensated via the S-parameter correction function. However, compensation by using a global offset or an offset table is always possible.

PC control

Hardware and software requirements

The following requirements must be met if the sensor is to be controlled by a PC via an interface adapter:

- The PC must have a USB port.
- The PC's operating system must support the USB port. This is the case with Windows™ 98, Windows™ ME, Windows™ 2000, Windows™ XP and more recent versions of the Windows™ operating system.
- The USB device drivers in the supplied *NRP Toolkit* software package must be installed.

If these requirements are met, the sensor can be controlled using a suitable application program such as the NrpFlashup program contained in the NRP Toolkit (includes the modules Power Viewer, USB Terminal, Firmware Update and Update S-Parameters).

When you insert the CD-ROM supplied with the R&S NRP, the NRP Toolkit is automatically installed on your PC. The rest of the procedure is self-explanatory.

The sensor can be powered in two ways:

- *Self-powered* from a separate power supply via the Active USB Adapter R&S NRP-Z3.
- *Bus-powered* from the PC or a USB hub with its own power supply (*self-powered hub*) via the Active USB Adapter R&S NRP-Z3 or via the Passive USB Adapter R&S NRP-Z4.

Because the sensor R&S NRP-Z5x has a maximum current capacity of 100 mA and is therefore classified as a low-power device, it can be supplied with current from any stationary PC, laptop or notebook in the bus-powered mode.

Operation via the Active USB Adapter R&S NRP-Z3

Fig. 1-3 shows the configuration with the Active USB Adapter R&S NRP-Z3, which also makes it possible to feed in a trigger signal for the *Timeslot* and *Scope* modes. The order in which the cables are connected is not critical.

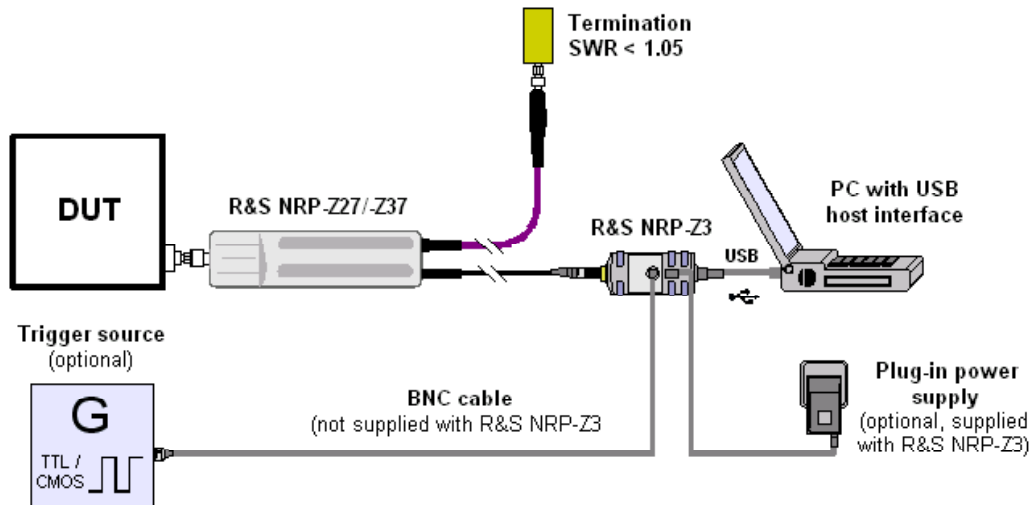

Fig. 1-3 Configuration with Active USB Adapter R&S NRP-Z3

The plug-in power supply for the R&S NRP-Z3 can be powered from a single-phase AC source with a nominal voltage range of 100 V to 240 V and a nominal frequency between 50 Hz and 60 Hz. The plug-in power supply autoselects to the applied AC voltage. No manual voltage selection is required.

The plug-in power supply comes with four primary adapters for Europe, the UK, the USA and Australia. No tools of any kind are required to change the primary adapter. The adapter is pulled out manually and another adapter inserted until it locks (Fig. 1-4).

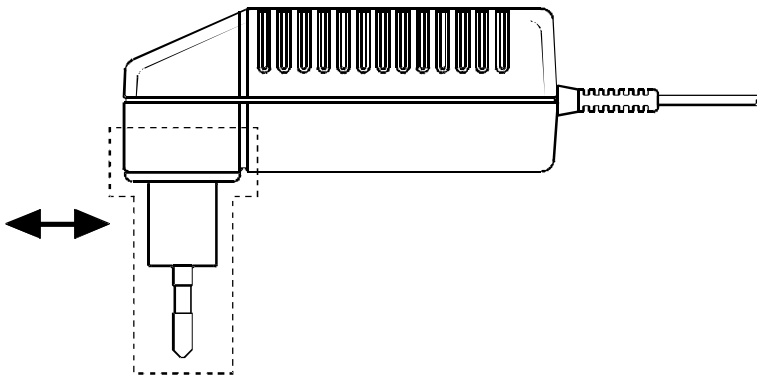

Fig. 1-4 Changing the primary adapter

The plug-in power supply is short-circuit-proof and has an internal fuse. It is not possible to replace this fuse or open the plug-in power supply.



The plug-in power supply is not intended for outdoor use.

Keep within the temperature range of 0°C to 50°C.

If there is any condensation on the plug-in power supply, dry it off before connecting it to the AC supply.

Operation via the Passive USB Adapter R&S NRP-Z4

Fig. 1-5 is a schematic of the measurement setup. The order in which the cables are connected is not critical.

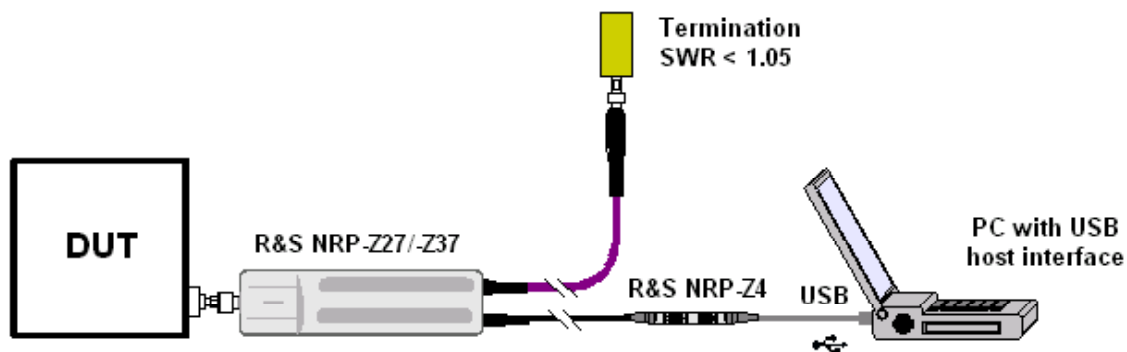

Fig. 1-5 Configuration with Passive USB Adapter R&S NRP-Z4

Connecting the sensor to the DUT

The power sensor modules have a male N connector (R&S NRP-Z27) or a male 3.5 mm connector (R&S NRP-Z37) on their RF input and can thus be connected to any standard female N or 2.92 mm/3.5 mm/SMA connector, respectively. To connect the power sensor module to the DUT more easily and without tilting it, relieve it by slightly lifting it.

Performing measurements

The R&S NRP uses the power sensor modules in the same manner as the thermal power sensors of the R&S NRP-Z5x series. An exception is the S-parameter correction function, which is always activated in the power sensor modules. This function takes the integrated power splitter into consideration. Therefore, the influence of adapters or attenuators which are connected ahead of the input of the power sensor module cannot be compensated via the S-parameter correction function. However, compensation by using a global offset or an offset table is always possible.

Table of Contents

2 Virtual Power Meter2.1

Overview.....2.1

 Menus2.3

Figs.

Fig. 2-1 **Power Viewer** virtual power meter2.1

Tables

Table 2-1 Virtual power meter keys2.2
Table 2-2 Virtual power meter entry fields2.2

2 Virtual Power Meter

You will find the **NrpFlashup** program that enables you to operate the power sensor module with a PC under Windows™ on the CD-ROM that accompanies the power sensor module. The program comprises several modules which can be started centrally via the Windows™ start-menu entry **NRP Toolkit**.

This section describes the **Power Viewer** program module. This is a virtual power meter which only uses a cut-down set of the sensor's functions. This means that after an extremely brief familiarization period, you can perform measurements.

The other modules in **NrpFlashup** are described in Chapter 3 of the operating manual (**Terminal** module) or in the service manual (**Firmware Update** module).

Overview

Start the virtual power meter using the **NRP Toolkit – Power Viewer** start-menu entry. The **Power Viewer** program window is displayed (Fig. 2-1).

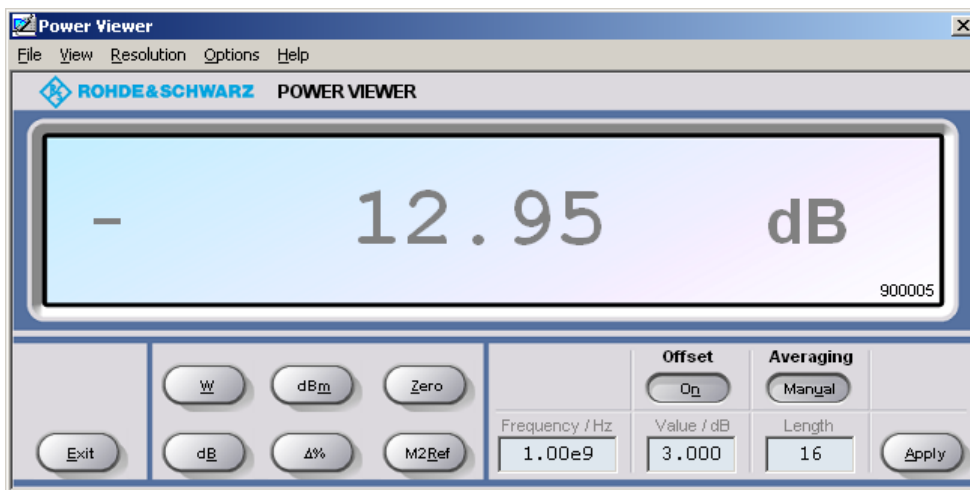

Fig. 2-1 **Power Viewer** – virtual power meter

The result display occupies most of the program window. The result, unit and additional power sensor module status information are displayed. The serial number of the sensor is displayed in the bottom right. The program window also contains animated buttons and entry fields (see Table 2-1 and Table 2-2).

Table 2-1 Virtual power meter keys

Button	Function	Key combination
Exit	Terminates the program. The current settings are saved and recalled the next time the program is started.	Alt + E
W	Selects Watt as the display unit.	Alt + W
dBm	Selects dBm as the display unit.	Alt + M
Zero	Zeroes the power sensor module.	Alt + Z
dB	Selects dB as the display unit. This is the log of the ratio of the measured value to the reference value.	Alt + B
Δ%	Selects % as the display unit. The difference between the measured value and the reference value is expressed as a percentage.	Alt + %
M2Ref	Makes the current measured value the reference value for the relative display units dB and %.	Alt + R
Offset On/Off	Turns the global offset correction for the power sensor module on or off. If the offset correction is Off, the Offset/dB entry field has a grey background.	Alt + N
Averaging Man/Auto	Turns auto-averaging on or off. When auto-averaging is on, the Length entry field has a grey background; the current averaging factor is displayed.	Alt + T
Apply	Accepts edited numerical values in the Frequency/Hz , Value/dB and Length entry fields and transfers them to the sensor.	Alt + A or Enter key

Table 2-2 Virtual power meter entry fields

Entry field	Function
Frequency/Hz	Frequency of the RF carrier in Hertz.
Value/dB	Attenuation in dB of the component connected to the power sensor module. The valid range is -100 to 100. The offset correction must be activated beforehand with the Offset On/Off button if this entry field is to be edited.
Length	Length of the averaging filter (= averaging factor). The valid range is 1 to 65536. Averaging must be set to manual with the Averaging Man/Auto button if this entry field is to be edited.

Scientific notation can also be used for the entry fields. If an invalid entry is made, an error message is output. An edited numerical value will not be transferred to the power sensor module unless you use the **Apply** button or the Enter key to terminate the entry.

Menus

The menu bar can be used to call less frequently used functions.

File **Start Log ...** Opens a file-selection dialog to specify the path and name of the log file. Clicking the **Save** button starts the recording. All displayed values are written line-by-line to the log file with the date (format: YY/MM/DD) and time (format: hh:mm:ss.ms). Example:
-22.51 dBm (03/02/25 15:37:25.310)

Stop Log Ends the log-file recording.

View **Display Refresh Rate** Opens a dialog box to adjust the display refresh rate. The time in milliseconds between two refresh operations is entered. The default setting is 200 ms.



Colours Opens a dialog box to select the background colour for

- the result,
- the unit,
- the text in the number fields or
- the key labelling.

**Result
Unit
Edit
Button**

Resolution For setting the result resolution. If auto-averaging has been selected, a higher resolution leads to a greater averaging factor, which means a longer result settling time.

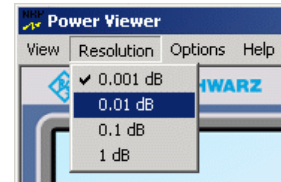

Options **Read Sensor Status ...** Reads the current status of the power sensor module. A parameter list is output.

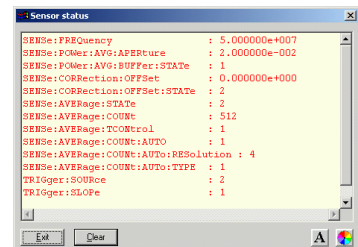

Read Error Queue ...

Reads the error queue. All the error messages that have been issued since the last call are read line-by-line. A tick before this menu entry indicates that an error has occurred.

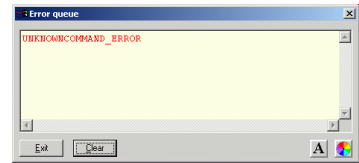

Simulation ...

Allows you to try out the functions of the virtual power meter even without a power sensor module. The display alternates between **Measurement Value 1 & Measurement Value 2** with a period given by **Interval**. Simulation can be activated immediately with the **Activate** check box.

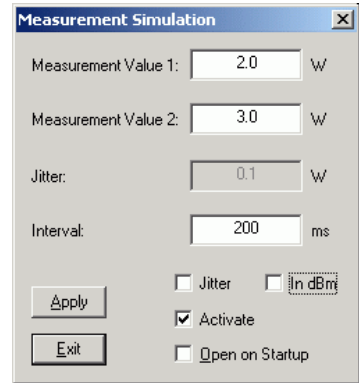

Reset Sensor

Initializes the power sensor module. Any previous zeroing remains valid.

Help

Contents

Opens the table of contents for the online-help facility.

About

Displays information about the program version used, etc.

Table of Contents

- 3 Manual Operation3.1**
- Program module "Terminal"3.1**
 - Main control elements.....3.1
 - Menus3.3
- Program module "Firmware Update"3.7**

Figs.

Fig. 3-1 Sending commands using the **Input** field3.2
Fig. 3-2 Sending commands using command files3.2

Tables

Table 3-1 Buttons assigned to the **Input** field3.2
Table 3-2 Buttons assigned to the **Command File** field3.3
Table 3-3 Buttons assigned to the **Output** field3.3

3 Manual Operation

The previous section describes the Power Viewer program module supplied with the instrument. This module simplifies the most frequently used function of a power meter – measuring the average power of an RF signal. Other program modules are also part of the supplied equipment and can be selected in the Start menu:

- **Power Viewer:** A detailed description of this virtual power meter module is provided in section 2.
- **Terminal:** Program module for sending commands and command sequences to the power sensor module and for displaying measurement results, status information and other data from the sensor
- **Firmware Update:** Program module for updating the firmware in the power sensor module.
- **Update S-Parameters:** Program module for loading an s-parameter table into the sensor. The power splitter integrated in the power sensor module already occupies this data record. Thus, any adapters or attenuators connected ahead of the power sensor modules cannot be taken into consideration via the S-parameter correction function. Since overwriting the existing data record would result in the loss of the functionality of the power sensor module, *Update S-Parameters* is not further described.

Program module "Terminal"

Main control elements

With the USB terminal, commands and command sequences can be sent to the power sensor module in two different ways:

- Commands are entered in the **Input** field (Fig. 3-1). Consecutive commands can be entered as separate lines, one below the other. The buttons associated with the **Input** field are described in Table 3-1.
- Commands or command sequences are stored in *command files*. Command files are created with a text editor, for instance, and then stored. They can be called as often as required (Fig. 3-2). The buttons of the **Command File** field are described in Table 3-2.

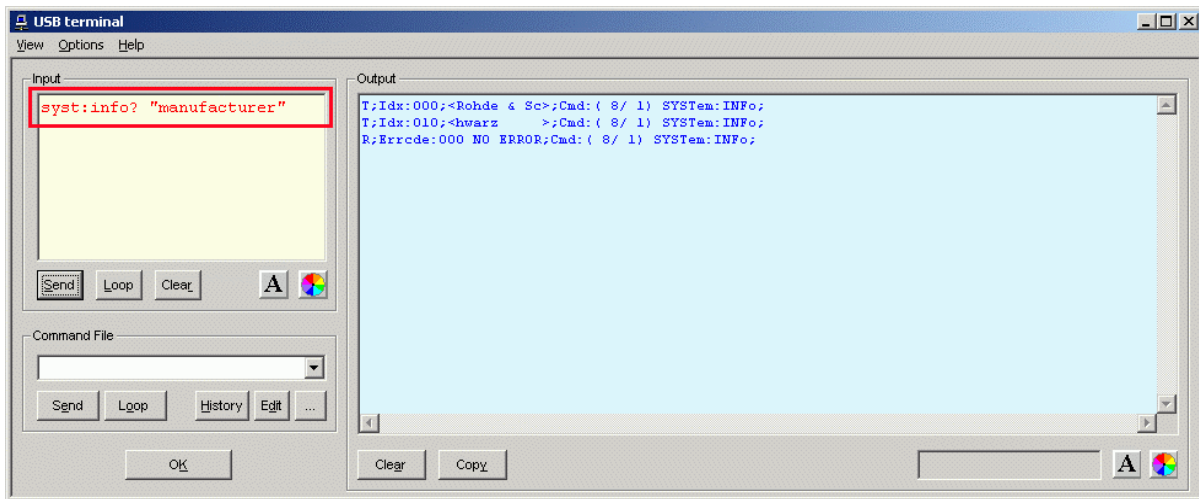

Fig. 3-1 Sending commands using the **Input** field

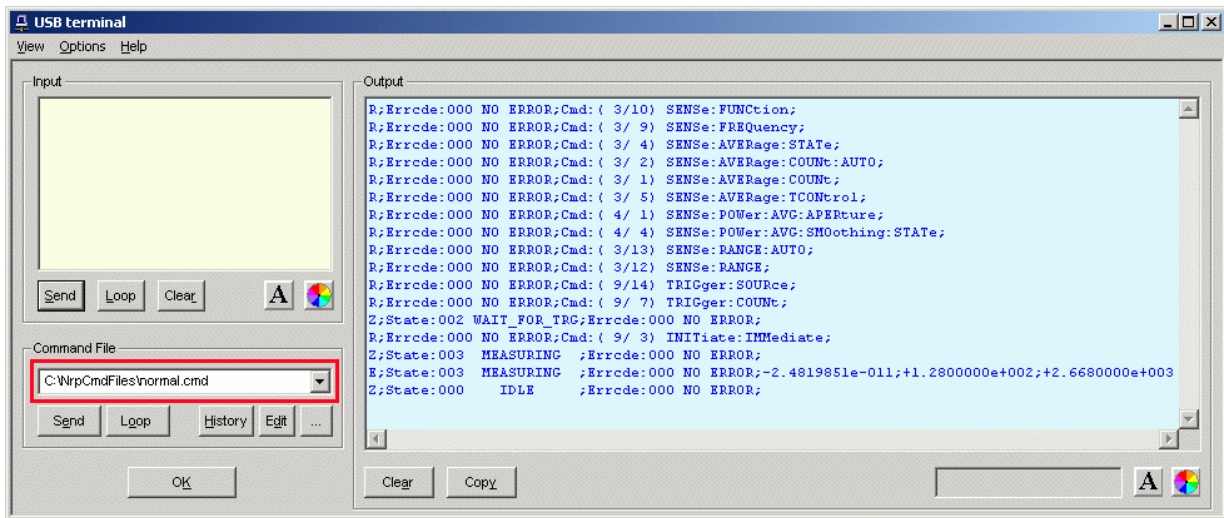

Fig. 3-2 Sending commands using command files

Table 3-1 Buttons assigned to the **Input** field

Button	Function	Key combination
Send	Sends the content of the Input entry field to the power sensor module.	Alt + S
Loop	With Loop the command or command sequence is cyclically sent. Pressing the button again terminates the cyclic transmission. The repetition rate is set in a dialog window that can be opened with View - Loop...	Alt + L
Clear	Clears the content of the Input field.	Alt + R
Font key	Opens a dialog window where the font for the Input field can be selected.	
Colour key	Opens a dialog window where the background colour of the Input field can be selected.	

Table 3-2 Buttons assigned to the **Command File** field

Button	Function	Key combination
Send	Sends the content of the command file to the power sensor module.	Alt + E
Loop	With Loop the command or command sequence is cyclically sent. Pressing the button again terminates the cyclic transmission. The repetition rate is set in a dialog window that can be opened with View - Loop...	Alt + O
History	Opens a window for editing the command file name in the Command File field.	Alt + H
Edit	Opens the selected command file in the Windows™ text editor.	Alt + D
...	Opens a file opening dialog for selecting the command file.	

A command line starting with a tab, a blank or a special character is considered a comment and not forwarded to the power sensor module.

Measurement results, parameters and status information that are returned are displayed in the **Output** field.

Table 3-3 Buttons assigned to the **Output** field

Button	Function	Key combination
Clear	Clears the content of the Output field	Alt + A
Copy	Copies the content of the Output field to the clipboard. (Another possibility: mark the desired information in the output window with the mouse cursor, press the right mouse key or Ctrl+C and then copy the selected text to the clipboard using the menu item Copy in the opened context menu.)	Alt + Y
Font button	Opens a dialog window where the font for the Output field can be selected.	
Colour button	Opens a dialog window where the background colour of the Output field can be selected.	

Close the USB terminal with OK.

Menus

View **Post Filter ...** Opens the **Output Postfilter** dialog window where the lines stored in the input buffer can be filtered according to different criteria.

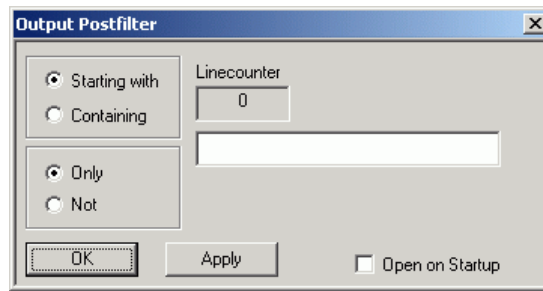

Filter criteria:

Only + Starting with: Only lines starting with the entered character string are displayed.

Not + Starting with: Only lines not starting with the entered character string are displayed.

Only + Containing: Only lines containing the entered character string are displayed.

Not + Containing: Only lines not containing the entered character string are displayed.

Lines not matching the specific filter criterion are blanked but not cleared.

Filtering is started with **Apply**. The number of lines matching the filter criterion is displayed in the **Linecounter** field. If **Open on startup** is active, the **Output Postfilter** dialog is automatically opened when the terminal is started. The dialog window is closed with **OK**.

Response Time ...

Opens the **Response time** dialog window where the response time of the power sensor module can be set.

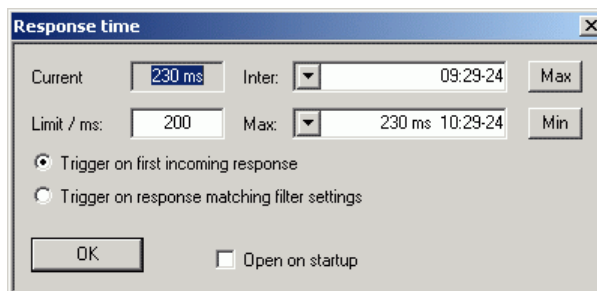

Current indicates the time elapsed between dispatch of the last command and receipt of an acknowledgement from the power sensor module.

When the **Max** button is clicked, the response times exceeding the value in the **limit / ms** field are recorded. When the **Min** button is clicked, the response times within the value in the **limit / ms** field are recorded.

If **Trigger on first incoming response** is active, the time measurement is terminated as soon as the first response arrives after a command is sent. If **Trigger on response matching filter settings** is active, the time measurement is terminated as soon as the first response matching the filter criterion in the **Output Postfilter** dialog window is received.

If **Open on startup** is active, the **Response Time** dialog is automatically displayed when the Terminal module is started. The dialog window is closed with **OK**.

Loop ...

Opens the **Loop controls** dialog window where the cyclic transfer of commands and command sequences can be controlled.

In the **Delay / ms** field, the time interval for the cyclic transfer is specified in milliseconds.

The number of completed transfer cycles is displayed in the **Counter** field. If **Open on startup** is active, the **Response time** dialog is automatically opened when the Terminal module is started. The dialog window is closed with **OK**.

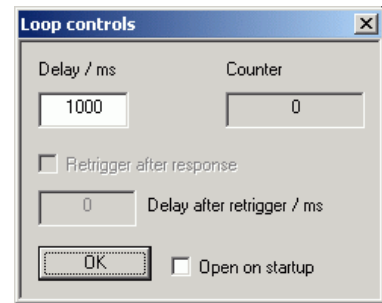

Options	Protocol Mode	In this mode, a time stamp is added to each response block.
	Hex Mode	In this mode, the response blocks from the sensor are displayed in hexadecimal format.
	Auto Delete	With this option active, the Output field is automatically cleared when the Send button is pressed.
	Auto Scroll	With this option active, older items in the Output field are automatically shifted upward and off the display if space is required for new values.
	LF at EOT	With this option active, a line feed is appended to each response block from the sensor.
	Delete on Start	With this option active, the Output field is automatically cleared when the Terminal module is started.
	Send as Hex	With this option active, the text in the Input field is interpreted as a hexadecimal character sequence.
	Advanced ...	Opens a dialog window where the buffer size for the Output field can be set.

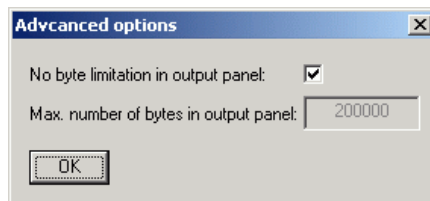
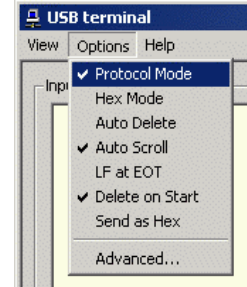

Help	Contents	Opens the table of contents for the online help.
	About	Displays information about the program version, etc.

Program module "Firmware Update"

A detailed description of the program module for firmware updates is provided in the Service Manual.

Table of Contents

5 Remote Control – Fundamentals5.1

5 Remote Control – Fundamentals

Rohde & Schwarz recommends to utilize the VXI Plug & Play Driver for the remote control of R&S NRP power sensors and power sensor modules. This driver can be found on the CD-ROM supplied with the sensor or downloaded in its most recent version via the internet (<http://rohde-schwarz.com/>).

The old remote control interface provided by the *Dynamic Link Library NrpControl.dll* is not developed further, but remains on the CD-ROM and can be downloaded via the internet.

Table of Contents

6 Remote Control – Commands	6.1
Notation	6.1
Commands as per IEEE 488.2	6.2
*IDN? – Identification Query	6.2
*RST – Reset	6.2
*TRG – Trigger.....	6.2
*TST? – Self Test Query.....	6.2
SCPI Commands	6.3
CALibration	6.3
CALibration:DATA[?] <calibration data set as <i>definite length block</i> >	6.3
CALibration:DATA:LENGth?.....	6.3
CALibration:ZERO:AUTO[?] OFF ON ONCE	6.4
SENSe (Power Sensor Module Configuration).....	6.5
SENSe:AVERAge:COUNt[?] 1 to 65536.....	6.6
SENSe:AVERAge:COUNt:AUTO[?] OFF ON ONCE.....	6.6
SENSe:AVERAge:COUNt:AUTO:MTIME[?] 1.0 to 999.99	6.7
SENSe:AVERAge:COUNt:AUTO:NSRatio[?] 0.0001 to 1.0	6.7
SENSe:AVERAge:COUNt:AUTO:RESolution[?] 1 to 4	6.7
SENSe:AVERAge:COUNt:AUTO:TYPE[?] RESolution NSRatio.....	6.7
SENSe:AVERAge:RESet	6.7
SENSe:AVERAge:STATE[?] OFF ON	6.8
SENSe:AVERAge:TCONtroll[?] MOVing REPeat.....	6.8
SENSe:CORRection:DCYClE[?] 0.001 to 99.999.....	6.8
SENSe:CORRection:DCYClE:STATE[?] OFF ON	6.8
SENSe:CORRection:OFFSet[?] –200.0 to 200.0	6.9
SENSe:CORRection:OFFSet:STATE[?] OFF ON	6.9
SENSe:FREQUency[?] 10.0e3 to 18.0e9 (R&S NRP-Z27) or 26.5e9 (R&S NRP-Z37) ..	6.9
SENSe:FUNcTION[?] <sensor_function>.....	6.10
SENSe:POWer:AVG:APERture[?] 0.001 to 0.3	6.10
SENSe:POWer:AVG:BUFFer:SIZE[?] 1 to 1024.....	6.11
SENSe:POWer:AVG:BUFFer:STATE[?] OFF ON	6.11
SENSe:POWer:AVG:SMOothing:STATE[?] OFF ON.....	6.11
SENSe:SGAMma:CORRection:STATE[?] OFF ON	6.12
SENSe:SGAMma:MAGNitude[?] 0.0 to 1.0.....	6.12
SENSe:SGAMma:PHASe[?] –360.0 to 360.0.....	6.12
SENSe:RGAMma:MAGNitude[?] 0.0 to 1.0.....	6.12
SENSe:RGAMma:PHASe[?] –360.0 ... 360.0.....	6.12

SYSTem.....	6.13
SYSTem:INFO? [Item].....	6.13
SYSTem:INITialize.....	6.14
SYSTem:MINPower?.....	6.15
SYSTem:TRANsaction:BEgin.....	6.15
SYSTem:TRANsaction:END.....	6.15
TEST.....	6.16
TEST:SENSor?.....	6.16
TRIGger.....	6.17
ABORt.....	6.17
INITiate:CONTinuous[?] OFF ON.....	6.17
INITiate:IMMediate.....	6.18
TRIGger:COUNt[?] 1 to 2×10^9	6.18
TRIGger:DELay[?] 0 to 100.0.....	6.18
TRIGger:DELay:AUTO[?] OFF ON.....	6.18
TRIGger:HOLDoff[?] 0.0 to 10.0.....	6.19
TRIGger:HYSTeresis[?] 0.0 to 10.0.....	6.19
TRIGger:IMMediate.....	6.19
TRIGger:LEVel[?] x to y.....	6.19
TRIGger:SLOPe[?] POSitive NEGative.....	6.20
TRIGger:SOURce[?] BUS EXTernal HOLD IMMediate INTernal.....	6.20
List of Remote-Control Commands.....	6.21

Tables

Table 6-1	Commands of the <i>CALibration</i> system	6.3
Table 6-2	Commands of the <i>SENSe</i> system	6.5
Table 6-3	Measurement mode "POWer:AVG"	6.10
Table 6-4	Optimum selection of the sampling window size (N = 1, 2, 3, ...)	6.10
Table 6-5	Commands of the <i>SYSTem</i> system.....	6.13
Table 6-6	Meaning of <i>Item</i> in the <i>SYSTem:INFO?</i> command	6.13
Table 6-7	Commands of the <i>TEST</i> system	6.16
Table 6-8	Commands of the <i>TRIGger</i> system	6.17
Table 6-9	List of remote-control commands.....	6.21

6 Remote Control – Commands

Notation

In the following sections, all commands implemented in the power sensor module are first listed in a table according to command systems and are then described in detail. The notation is largely in line with the SCPI standard.

Command tables For a quick overview of available commands, the commands are listed in a table before they are described. These tables contain the following four columns:

Command:	Commands and their tree structure.
Parameters:	Possible parameters.
Unit:	The basic unit of the physical parameters (must not be sent with parameters).
Remarks:	Identification of all commands <ul style="list-style-type: none"> • that have no query form • that are available as query only

Indentations The various levels of the SCPI command hierarchy are shown in the table by indentations to the right. The lower the level, the greater the indentation to the right. It should be noted that the complete notation of the command includes the higher levels too.

Example:

SENSe:AVERage:COUNt is represented in the table as follows:

```
SENSe      first level
  :AVERage  second level
    :COUNt  third level
```

In the individual description, the command is shown in full length. An example of the command is given at the end of the description.

[?]
?

A question mark in square brackets at the end of a command indicates that this command can either be used as a setting command (without question mark) or as a query (with question mark). If the question mark is not in square brackets, the command is a query only.

Example:

SENSe:POWer:AVG:APERture[?]

SENSe:POWer:AVG:APERture 1e-3 sets the length of the sampling window to 1 ms.

SENSe:POWer:AVG:APERture? Returns the currently set length as a response.

**IDN?* Queries the identification string of the power sensor module that of course cannot be changed. For this reason, this command is only available as a query.

Special characters | for parameters

A vertical bar between parameters is used to separate alternative options (OR link).

Example:

NITiate:CONTInuous OFF | ON

The parameter *OFF* or *ON* can be entered.

{numeric expression}

A numeric expression in braces means that it has been rounded to the nearest integral value.

**<parameter>
<variable>**

A parameter or a variable in triangular brackets expresses its current value.

Commands as per IEEE 488.2

The power sensor module supports a subset of the possible setting commands and queries (*Common Commands and Queries*) in line with IEEE 488.2.

*IDN? – Identification Query

*IDN? returns a string with information on the power sensor module's identity (device identification code). In addition, the version number of the installed firmware is indicated. The string for a power sensor module of type R&S NRP-Z27/-Z37 has the following structure:

ROHDE&SCHWARZ,NRP-Zx7,<serial number>,<firmware version>

<serial number>: Serial number in ASCII

<firmware version>: Firmware version number in ASCII

*RST – Reset

*RST sets the power sensor module to the default state, i.e. the default settings for all test parameters are loaded.

*TRG – Trigger

*TRG triggers a measurement. For this purpose, the power sensor module is in the *WAIT_FOR_TRIGGER* state and the source for the trigger event is set to *BUS (TRIGger:SOURce BUS)*.

*TST? – Self Test Query

*TST? starts a selftest and returns 0 (no error found) or 1 (an error has occurred). The selftest comprises the following functions:

- RAM test
- Operating voltages
- Temperature measurement
- Calibration data set
- Noise
- Zero-point offsets.

SCPI Commands

The power sensor module R&S NRP-Z27/-Z37 is controlled via the groups of commands

- CALibration (zeroing)
- SENSE (measurement configurations)
- SYSTem
- TRIGger
- SERVICE.

CALibration

Table 6-1 Commands of the CALibration system

Command	Parameter	Unit	Remarks
CALibration			
:DATA[?]	<calibration data set as definite length block>		
:LENGth?		Bytes	Query only
:ZERO			
:AUTO[?]	OFF ON ONCE		

CALibration:DATA[?] <calibration data set as *definite length block*>

CALibration:DATA is used for writing a calibration data set in the flash memory of the power module sensor.

The query yields the calibration data set currently stored in the flash memory as a *definite length block*.

CALibration:DATA:LENGth?

CALibration:DATA:LENGth? yields the length in bytes of the calibration data set currently stored in the flash memory. Programs that read out the calibration data set can use this information to determine the capacity of the buffer memory required.

CALibration:ZERO:AUTO[?] OFF | ON | ONCE

The commands *CALibration:ZERO:AUTO ON* and *CALibration:ZERO:AUTO ONCE* perform zeroing. For this purpose, the test signal must be deactivated or the power sensor module disconnected from the signal source. The power sensor module automatically detects the presence of any significant power to be measured. This causes zeroing to be aborted and error message *NRPEROR_CALZERO* to be output. The *CALibration:ZERO:AUTO OFF* is ignored. Zeroing takes four seconds at a minimum, but at least as long as the selected averaging filter needs for settling (only fixed-filter mode).

*Repeat zeroing*

- *during warm-up after switching on or connecting the instrument*
- *after a substantial variation of the ambient temperature*
- *after fastening the power sensor module to an RF connector at high temperature*
- *after several hours of operation*
- *when very low-power signals are to be measured, e.g. less than 10 dB above the lower measurement limit.*

For zeroing switch off the test signal and do not remove the power sensor module from the signal source. Apart from keeping the thermal balance, this has the advantage that the noise superimposed on the test signal (e.g. from a broadband amplifier) can be detected on zeroing and does not impair the measurement result.

The query always yields 1 (= OFF).

Default setting

After a power-on reset, the zero offsets determined during the last calibration are used until the first zeroing. Therefore, very slight zero offsets are to be expected with a warmed up power sensor module. Initialization by means of **RST* or *SYSTem:INITialize* has no influence on the current zero offsets.

SENSe (Power Sensor Module Configuration)

The power sensor module is configured by means of the commands of the groups *SENSe* and *TRIGger*.

Table 6-2 Commands of the *SENSe* system

Command	Parameter	Unit	Remarks
SENSe			
:AVERage			
:RESet			No query
:STATe[?]	OFF ON		
:TCONtrol[?]	MOVing REPeat		
:COUNt[?]	1 to 65536		
:AUTO[?]	OFF ON ONCE		
:TYPE[?]	RESolution NSRatio		
:MTIME[?]	1.0 to 999.99	s	
:NSRatio[?]	0.0001 to 1.0	dB	
:RESolution[?]	1 to 4		
:CORRection			
:OFFSet[?]	-200.0 to 200.0	dB	
:STATe[?]	OFF to ON		
:DCYClE[?]	0.001 to 99.999	%	
:STATe[?]	OFF to ON		
:FREQuency[?]	1.0e3 to 18.0e9 (NRP-Z27) or 26.5e9 (NRP-Z37)	Hz	
:FUNction[?]	"POWer:AVG"		
:POWer			
:AVG			
:APERture[?]	0.001 to 0.3	s	
:BUFFer			
:STATe[?]	OFF ON		
:SIZE[?]	1 to 1024		

Command	Parameter	Unit	Remarks
:SMOothing:STATe[?]	OFF ON		
:SGAMma			
:CORRection:STATe[?]	OFF ON		
:MAGNitude[?]	0.0 to 1.0		
:PHASe[?]	-360.0 to 360.0	degree	
:RGAMma			
:MAGNitude[?]	0.0 to 1.0		
:PHASe[?]	-360.0 to 360.0		

SENSe:AVERage:COUNT[?] 1 to 65536

SENSe:AVERage:COUNT sets the number of measured values that have to be averaged for forming the measurement result. The higher this averaging factor, the less the measured values fluctuate and the longer the measurement time lasts. The parameter is rounded off to the nearest power-of-two number.

The query yields the averaging factor used.



The averaging function must be activated with SENSe:AVERage:STATe ON so that the set averaging factor becomes effective.

Default setting: 4

SENSe:AVERage:COUNT:AUTO[?] OFF | ON | ONCE

SENSe:AVERage:COUNT:AUTO activates (auto-averaging) or deactivates (fixed-filter mode) automatic determination of the averaging factor. If auto-averaging is activated, the averaging factor is continuously determined and set depending on the level of power and other parameters.

SENSe:AVERage:COUNT:AUTO ON activates auto-averaging and SENSe:AVERage:COUNT:AUTO OFF deactivates it. On deactivation, the previous, automatically determined averaging factor is used in the fixed-filter mode. The SENSe:AVERage:COUNT:AUTO ONCE command ensures that a new averaging factor is determined by the filter automatic function under the current measurement conditions and used in the fixed-filter mode.

The query yields

- 1 for OFF,
- 2 for ON.

Default setting: OFF

SENSe:AVERage:COUNT:AUTO:MTIME[?] 1.0 to 999.99

SENSe:AVERage:COUNT:AUTO:MTIME sets the settling time upper limit of the averaging filter in the auto-averaging mode and limits the length of the filter.

The query yields the current settling time upper limit of the averaging filter.

Default setting: 30.0 [s]

SENSe:AVERage:COUNT:AUTO:NSRatio[?] 0.0001 to 1.0

SENSe:AVERage:COUNT:AUTO:NSRatio determines the relative noise component in the measurement result if auto-averaging is operated in the corresponding mode (*SENSe:AVERage:COUNT:AUTO:TYPE NSRatio*). The noise component is defined as the magnitude of the level variation in dB caused by the inherent noise of the power sensor module (two standard deviations).

The query yields the relative noise component in the result.

Default setting: 0.01 [dB]

SENSe:AVERage:COUNT:AUTO:RESolution[?] 1 to 4

SENSe:AVERage:COUNT:AUTO:RESolution sets the resolution index for the automatic averaging filter. The resolution index equals the number of decimal places that have to be taken into account for the further processing of the measurement result in dBm, dB μ V or dB. The normal mode is designed in a similar manner as for the predecessors R&S NRVS and R&S NRVD or other commercial power meters. The higher the selected index, the better the measurement result is filtered without the last significant place (0.01 dB with an index of 3) actually being set. The *NSRatio* setting is recommended instead.

The query yields the resolution index.

Default setting: 3

SENSe:AVERage:COUNT:AUTO:TYPE[?] RESolution | NSRatio

SENSe:AVERage:COUNT:AUTO:TYPE defines the automatic averaging filter mode. The *RESolution* parameter sets the mode usual for power meters; *NSRatio* predefines the compliance to an exactly defined noise component.

The query yields

- 1 for *RESolution*,
- 2 for *NSRatio*.

Default setting: *RESolution*

SENSe:AVERage:RESet

SENSe:AVERage:RESet initializes the averaging filter. This is useful if a high averaging factor is set in the *SENSe:AVERage:TCONTROL MOVing* filter mode and if the power to be measured has significantly decreased since the previous measurement, e.g. by several powers of ten. In this case, previous measurement results still contained in the averaging filter strongly affect the settling of the display; as a result, the advantage of the *SENSe:AVERage:TCONTROL MOVing* filter mode, i.e. the ability to detect trends in the measurement result while the measurement is still in progress, is lost. The *SENSe:AVERage:RESet* command solves this problem by deleting all previous measurement results that the averaging filter contains. After initialization, the filter length gradually increases from 1 to its nominal value *SENSe:AVERage:COUNT*, so that trends in the measurement result become quickly

apparent. However, this procedure does not shorten the measurement time required in order for the averaging filter to settle completely.

SENSe:AVERage:STATe[?] OFF | ON

SENSe:AVERage:STATe switches on or off the averaging filter.

The query yields

- 1 for *OFF*,
- 2 for *ON*.

Default setting: *ON*

SENSe:AVERage:TCONtrol[?] MOVing | REPeat

SENSe:AVERage:TCONtrol (*terminal control*) defines the behaviour of the averaging filter. As soon as a new measured value is shifted to the FIR filter, a new average value is available at the filter output, which is obtained from the new measured value and the other values stored in the filter.

The *MOVing* parameter defines that each new average value is output as a measurement result. This allows tendencies in the result to be recognized during the measurement procedure.

The *REPeat* parameter defines that a new result is output after the FIR filter has been filled with new measured values. This ensures that no redundant information is output.

The query yields

- 1 for *MOVing*,
- 2 for *REPeat*.

Default setting: *MOVing*

SENSe:CORRection:DCYClE[?] 0.001 to 99.999

SENSe:CORRection:DCYClE sets the duty cycle to a percent value for the correction of pulse-modulated signals. With the correction activated, the power sensor module calculates the signal pulse power from this value and the mean power.

The query yields the current duty cycle in percent.

Default setting: *1.0 [%]*

SENSe:CORRection:DCYClE:STATe[?] OFF | ON

SENSe:CORRection:DCYClE:STATe ON activates the duty cycle correction and thus the pulse-power measurement whereas *SENSe:CORRection:DCYClE:STATe OFF* deactivates it.

The query yields

- 1 for *OFF*,
- 2 for *ON*.

Default setting: *OFF*

SENSe:CORRection:OFFSet[?] -200.0 to 200.0

SENSe:CORRection:OFFSet defines a fixed offset in dB, which is used to correct the measured value. (When a log scale is used, the offset is added to the measured value; this is the reason why the command has this name.)

The attenuation of an attenuator located ahead of the power sensor module or the coupling attenuation of a directional coupler is taken into account with a positive offset, i.e. the power sensor module calculates the power at the input of the attenuator or directional coupler. A negative offset can be used to correct the influence of a gain connected ahead.

The query yields the set offset in dB.

Default setting: *0.0 [dB]*

SENSe:CORRection:OFFSet:STATe[?] OFF | ON

SENSe:CORRection:OFFSet:STATe ON activates the offset correction and *SENSe:CORRection:OFFSet:STATe OFF* deactivates it.

The query yields

- 1 for *OFF*,
- 2 for *ON*.

Default setting: *OFF*

SENSe:FREQuency[?] 10.0e3 to 18.0e9 (R&S NRP-Z27) or 26.5e9 (R&S NRP-Z37)

SENSe:FREQuency transfers the carrier frequency of the RF signal to be measured; this frequency is used for the frequency-response correction of the measurement result. The center frequency is set for broadband signals (*spread-spectrum* signals, multicarrier signals).

The query yields the set carrier frequency in Hz.

Default setting: *50.0e6 [Hz]*

SENSe:FUNcTION[?] <sensor_function>

In contrast to other sensors of the R&S NRP-Z series, the power sensor modules only implement the *Continuous Average* mode. Therefore, the command *SENSe:FUNcTION <sensor_function>* only accepts the parameter *"POWer:AVG"*.

Table 6-3 Measurement mode "POWer:AVG"

<sensor_function>	Description of the measurement mode
"POWer:AVG"	<p>Continuous Average After occurrence of the trigger event, the mean power is measured in a time interval (sampling window) whose width is defined with <i>SENSe:POWer:AVG:APERTure</i>. The single measurements are performed in pairs to obtain a more accurate measurement result by differentiation. With the averaging function activated, this operation is repeated the number of times specified by the averaging factor. With the averaging function activated, the actual measurement time is thus $2 \times \langle \text{SENSe:AVERage:COUNT} \rangle \times \langle \text{SENSe:POWer:AVG:APERTure} \rangle$ and with deactivated averaging function $2 \times \langle \text{SENSe:POWer:AVG:APERTure} \rangle$. Trigger events start one or several measurements in the Continuous Average mode (depending on the <i>TRIGger:COUNT</i> parameter).</p>

The query always yields 1 for *"POWer:AVG"*.

Default setting: *"POWer:AVG"*

SENSe:POWer:AVG:APERTure[?] 0.001 to 0.3

SENSe:POWer:AVG:APERTure defines the time interval (sampling window); measured values are continuously recorded in this interval. In manual operation, the default setting of 20 ms in conjunction with the activated smoothing (see *SENSe:POWer:AVG:SMOothing:STATe*) is sufficient in most cases. Another value, which is normally higher, is required when the measurement result shows variations due to modulation. Especially with low-frequency modulation, it is useful to adapt the size of the sampling window exactly to the modulation period, which yields an optimum stable display.

Table 6-4 Optimum selection of the sampling window size (N = 1, 2, 3, ...)

Smoothing	Optimum sampling window size
OFF	$N \times \text{modulation period} / 2$
ON	$N \times \text{modulation period} \times 2$

The theoretically shortest measurement time can then be obtained only with smoothing deactivated. The situation is somewhat different when the sampling window cannot or should not be exactly adapted to the modulation period. Smoothing should then be activated since even one measurement window length of 5 periods is sufficient to reduce variations due to modulation to an acceptable extent; variations are no longer perceptible with more than 9 periods. With smoothing deactivated, the situation is significantly unfavourable. In this case, 5 instead of 300 periods are required and the variations completely disappear as of 3000 periods.

The query yields the currently set width of the sampling window in seconds.

Default setting: *0.02 [s]*

SENSe:POWer:AVG:BUFFer:SIZE[?] 1 to 1024

SENSe:POWer:AVG:BUFFer:SIZE sets the buffer size for the buffered *Continuous Average* mode.

The query yields the current buffer size for the buffered *Continuous Average* mode.

Default setting: 1

SENSe:POWer:AVG:BUFFer:STATe[?] OFF | ON

The buffered *Continuous Average* mode is activated with *ON* and deactivated with *OFF*. In this mode, the results generated by trigger events are collected in the power sensor module until the buffer is filled. All results are then transferred as block data. The measurement rate obtained is thus higher than in the non-buffered *Continuous Average* mode. The maximum measurement rate is obtained by combining the buffered mode with multiple triggering (see parameter *TRIGger:COUNT*). The size of the result buffer is set with the *SENSe:POWer:AVG:BUFFer:SIZE* command.

The query yields

- 1 for *OFF*,
- 2 for *ON*.

Default setting: *OFF*

SENSe:POWer:AVG:SMOothing:STATe[?] OFF | ON

The *ON* parameter activates a smoothing filter for modulated signals in the *Continuous Average* mode and *OFF* deactivates it. The smoothing filter is a steep-edge digital lowpass filter used to suppress variations of results caused by low-frequency modulation. This parameter should be activated to reduce variations in results due to modulation when the size of the sampling window cannot or should not be exactly adapted to the modulation period. If the selected sampling window is 5 to 9 times larger than a modulation period, the variations in display are normally sufficiently reduced. With smoothing deactivated, 300 to 3000 periods are required to obtain the same effect.

With smoothing deactivated, the sampling values are considered equivalent and averaged in a sampling window, which yields an integrating behaviour of the measuring instrument. As described above, optimum suppression of variations in the result is thus obtained when the size of the sampling window is exactly adapted to the modulation period. Otherwise, the modulation can have a considerable influence, even if the sampling window is much larger than the modulation period. The behaviour can be considerably improved by subjecting sampling values to weighting (raised-von-Hann window), which corresponds to video filtering. This is exactly what happens with activated smoothing.

Since the smoothing filter increases the inherent noise of the power sensor module by approx. 20 %, it should remain deactivated if it is not required.

The query yields

- 1 for *OFF*,
- 2 for *ON*.

Default setting: *ON*

SENSe:SGAMma:CORRection:STATe[?] OFF | ON

SENSe:SGAMma:CORRection:STATe ON activates the correction of the mismatch (gamma correction) between the power sensor module and the source. Gamma correction ensures that the power of the source available at 50 Ω is measured, whereas without correction only the power of the arriving wave is measured. For gamma correction, the complex reflection coefficient of the source is necessary (settings *SENSe:SGAMma:MAGNitude* und *SENSe:SGAMma:PHASe*).

The query yields

- 1 for OFF,
- 2 for ON.

Default setting: OFF

SENSe:SGAMma:MAGNitude[?] 0.0 to 1.0

SENSe:SGAMma:MAGNitude defines the magnitude of the complex reflection coefficient of the source. A value of 0.0 corresponds to an ideal matched source and a value of 1.0 to total reflection.

The query yields the set magnitude.

Default setting: 0.0

SENSe:SGAMma:PHASe[?] -360.0 to 360.0

SENSe:SGAMma:MAGNitude defines the phase angle (in degrees) of the complex reflection coefficient of the source.

The query yields the set phase angle.

Default setting: 0.0 [°]

SENSe:RGAMma:MAGNitude[?] 0.0 to 1.0

With the *SENSe:RGAMma* group of commands, you can compensate the load distortion at the signal output. Such compensation is necessary if the standing wave ratio exceeds a value of 1.05. Otherwise, you cannot comply with the data sheet specifications with regard to absolute accuracy.

For distortion compensation, you have to transfer the magnitude of the reflection coefficient of the load with the setting *SENSe:RGAMma:MAGNitude* and the phase angle with the setting *SENSe:RGAMma:PHASe*. To deactivate distortion compensation, set *SENSe:RGAMma:MAGNitude* to 0. An explicit switch-on/-off command, as is available in mismatch correction, does not exist. Distortion compensation should remain deactivated in the case of questionable measurement values for the reflection coefficient of the load.

The query yields the set magnitude.

Default setting: 0.0

SENSe:RGAMma:PHASe[?] -360.0 ... 360.0

SENSe:RGAMma:PHASe defines the phase angle (in degrees) of the complex reflection factor of the load at the signal output.

The query yields the set phase angle.

Default setting: 0.0 [°]

SYSTEM

With the aid of the *SYSTEM* system, administrative device settings can be defined and queried. This includes detailed information on the power sensor module and its initialization and the transfer of available commands and their parameter limits.

Table 6-5 Commands of the *SYSTEM* system

Command	Parameter	Unit	Remarks
SYSTEM			
:INFO? [Item]			Query only
:INITialize			No query
MINPower?		W	Query only
:TRANsaction			
:BEGIN:			No query
:END			No query

SYSTEM:INFO? [Item]

SYSTEM:INFO? yields a string containing information that is more detailed than the identification string delivered by the power sensor module as a response to **IDN?*. If no *Item* is specified, the response string is a sequence of entries in the form *Item:Information-String* separated by *CR* and *LF* (in C notation: $\backslash\r\n$). With the *Item* optionally appended to the command, the entry for the required *Item* can be queried. The response string is zero-terminated, i.e. its end identification is a zero byte (in C notation: $\backslash0$).

Table 6-6 Meaning of *Item* in the *SYSTEM:INFO?* command

Item	Information string	Remarks
"MANUFACTURER"	"Rohde & Schwarz GmbH & Co. KG"	Manufacturer
"TYPE"	"NRP-Z27" for R&S NRP-Z27" "NRP-Z37" for R&S NRP-Z37"	Type designation
"STOCK NUMBER"	"1169.4102.02" for R&S NRP-Z27" "1169.3206.02" for R&S NRP-Z37"	Material number
"SERIAL"	"<serial number>"	6-digit serial number
"HWVERSION"	"000000000"	Hardware version (standard)
"HWVARIANT"	"000000000"	Hardware model (standard)
"SW BUILD"	"<build number>"	Version number of firmware
"TECHNOLOGY"	"Thermal"	Detector technology used

Item	Information string	Remarks
"FUNCTION"	"Power Terminating"	Operating principle of a terminating power sensor.
"MINPOWER"	"<nominal lower test limit in W>"	The nominal lower test limit of power sensor modules is 4 μ W, i.e. with information string "4e-6" as a response to <i>SYSTem:INFo?</i> "MINPOWER".
"MAXPOWER"	"<nominal upper test limit in W>"	The nominal upper test limit of power sensor modules is 400 mW, i.e. with information string "0.4" as a response to <i>SYSTem:INFo?</i> "MAXPOWER".
"MINFREQ"	"<min. measuring frequency in Hz>"	The minimum measuring frequency is 1 kHz, i.e. the power sensor module returns the information string "1e+03" as a response to <i>SYSTem:INFo?</i> "MINFREQ".
"MAXFREQ"	"<max. measuring frequency in Hz>"	The maximum measuring frequency is 18 GHz for the R&S NRP-Z27, or 26.5 GHz for the R&S NRP-Z37, i.e. the power sensor module returns the information string "1.8e+10" or "2.65e+10", respectively, as a response to <i>SYSTem:INFo?</i> "MAXFREQ".
"IMPEDANCE"	"50"	The R&S NRP-Z5x RF input has a nominal input impedance of 50 Ω .
"COUPLING"	" DC"	The RF input of the power sensor modules is DC-coupled.
"CAL. ABS."	"<date>"	Date of absolute calibration in the format YYYY-MM-DD. "Invalid Calibration Date" is returned with an invalid date entry.
"CAL. REFL."	"<date>"	Date of matching calibration in the format YYYY-MM-DD.
"CAL. S PARA."	"<date>"	Date of s-parameter calibration in the format YYYY-MM-DD. If no S parameter set is loaded, the sensor returns the string "not applicable". "Invalid Calibration Date" is returned with an invalid date entry.
"CAL. MISC."	"<date>"	Date of the calibration of other parameters in the format YYYY-MM-DD. "Invalid Calibration Date" is returned with an invalid date entry.
"SPD MNEMONIC"	"<mnemonic string>"	Clear-text designation of the component connected ahead of the power sensor (e.g. "splitter")

SYSTem:INITialize

SYSTem:INITialize sets the power sensor module to the standard state, i.e. the default settings for all test parameters are loaded in the same way as with **RST*. The power sensor module then outputs a complete list of all supported commands and parameters. With the command, the remote-control software can automatically adapt to the features of different types of sensors with different functionality.

SYSTEM:MINPower?

SYSTEM:MINPower? yields the lower test limit of the power sensor module. This query can be used to determine a useful resolution for the result display near the lower test limit.

SYSTEM:TRANsaction:BEgIn

SYSTEM:TRANsaction:BEgIn marks the beginning of a sequence of setting commands between which the parameter limits must not be checked. This prevents the display of error messages when a setting command causes a conflict that is resolved by a subsequent setting command. See *SYSTEM:TRANsaction:END*.

SYSTEM:TRANsaction:END

SYSTEM:TRANsaction:END marks the end of a sequence of setting commands between which the parameter limits must not be checked. After this command, the parameter limits are checked.

TEST

Table 6-7 Commands of the TEST system

Command	Parameter	Unit	Remarks
TEST:SENSor?			Query only

TEST:SENSor?

TEST:SENSor? triggers a selftest of the power sensor module. In contrast to **TST*, this command yields detailed information, which is useful for troubleshooting.



No signal may be applied to the power sensor module while the selftest is running.

If the selftest is carried out with a signal being present, error messages may erroneously be output for the test steps "Offset Voltages" and/or "Noise Voltages".

TRIGger

Table 6-8 Commands of the TRIGger system

Command	Parameter	Unit	Remarks
ABORt			No query
INITiate			
:CONTInuous[?]	OFF ON		
:IMMediate			No query
TRIGger			
:COUNT[?]	1 to 2×10^9		
:DELay[?]	x to 100.0	s	
:AUTO[?]	OFF ON		
:HOLDoff[?]	0.0 to 10.0	s	
:HYSTeresis[?]	0.0 to 3.0	dB	
:IMMediate			No query
:LEVel[?]	x to y	W	
:SLOPe[?]	POSitive NEGative		
:SOURce[?]	BUS EXTernal HOLD IMMediate INTernal		

ABORt

ABORt interrupts the current measurement and sets the power sensor module to the *IDLE* state (normal case). However, if the power sensor module is in the continuous measurement mode (setting *INITiate:CONTInuous ON*), the *IDLE* state is immediately exited and the power sensor module enters the *WAIT_FOR_TRIGGER* state.

INITiate:CONTInuous[?] OFF | ON

INITiate:CONTInuous ON activates the continuous measurement mode. In this mode, a new measurement is automatically started when a measurement is terminated. The power sensor module first enters the *WAIT_FOR_TRIGGER* state and begins with the measurement as soon as the trigger condition is fulfilled. Once the measurement is completed, the sensor again enters the *WAIT_FOR_TRIGGER* state. The power sensor module will measure continuously assuming continuous trigger events.

In contrast, each measurement cycle must be explicitly started with the *INITiate:IMMediate* command after the *INITiate:CONTInuous OFF* command has been sent. After triggering and completion of the measurement, the power sensor module enters the *IDLE* status and remains in this status until a new measurement is started with the *INITiate:IMMediate* command.

The query yields

- 1 for OFF,
- 2 for ON.

Default setting: OFF

INITiate:IMMediate

INITiate:IMMediate starts a single measurement cycle. The power sensor module first changes from the *IDLE* state to the *WAIT_FOR_TRIGGER* state and begins with the measurement as soon as the trigger condition is fulfilled. Once the measurement is completed, the sensor again enters the *IDLE* state. Since the command is ignored during measurement, it normally has no effect in the continuous mode (setting *INITiate:CONTinuous ON*).

TRIGger:COUNT[?] 1 to 2×10^9

This setting is designed for applications in which several consecutive measurements have to be performed by sending the *INITiate:IMMediate* command only once, e.g. to obtain a higher measurement speed. The gap between a single measurement and the continuous measurement mode is thus closed. The number of measurements is defined with the parameter associated with the *TRIGger:COUNT* command. This number equals the number of results yielded by the power sensor module at the end of the measurement.



The TRIGger:COUNT command does not define the number of trigger events required for performing the entire measurement task. The number may vary depending on the measurement mode.

*A further increase in the measurement speed can be obtained by combining the mode used with the buffered mode. The results are not made available immediately but as a block at the end of the measurement sequence (see group commands *SENSe:POWer:AVG:BUFFer*).*

The query yields the number of measurements performed with the *INIT:IMMediate* command after a measurement start.

Default setting: 1

TRIGger:DELay[?] 0 to 100.0

TRIGger:DELay defines the delay (in seconds) between the occurrence of the trigger event and the beginning of the measurement itself.

The query yields the set trigger delay (in seconds).

Default setting: 0.0 [s]

TRIGger:DELay:AUTO[?] OFF | ON

TRIGger:DELay:AUTO ON ensures by means of an automatically determined delay that a measurement is only started after the test result has settled. This is important when thermal power sensor modules are used. The automatically determined delay is ignored if a longer period was set with *TRIGger:DELay*. This does not overwrite the value of *TRIGger:DELay*. *TRIGger:DELay:AUTO OFF* deactivates this function.

TRIGger:SLOPe[?] POSitive | NEGative

TRIGger:SLOPe defines the edge of the trigger event with internal and external triggering. In this connection, positive means increasing envelope power (with internal triggering) or increasing voltage (with external triggering). This command has no effect in conjunction with trigger sources *BUS*, *HOLD* and *IMMEDIATE*.

The query yields

- 1 for *POSitive*,
- 2 for *NEGative*.

Default setting: *POSitive*

TRIGger:SOURce[?] BUS | EXTernal | HOLD | IMMEDIATE | INTernal

TRIGger:SOURce sets the trigger source.

- *BUS*: Triggering with command **TRG* or *TRIGger:IMMEDIATE*.
- *EXTernal*: Triggering via USB Adapter R&S NRP-Z3. Relevant trigger parameters: *TRIGger:DELay* and *TRIGger:SLOPe*.
- *HOLD*: Triggering only with command *TRIGger:IMMEDIATE*.
- *IMMEDIATE*: Automatic triggering without explicit event.
- *INTernal*: Triggering by the measurement signal. Relevant trigger parameters: *TRIGger:LEVel*, *TRIGger:DELay* and *TRIGger:SLOPe*.

The query yields

- 1 for *BUS*,
- 2 for *EXTernal*,
- 4 for *HOLD*,
- 8 for *IMMEDIATE*,
- 16 for *INTernal*.

Default setting: *IMMEDIATE*

List of Remote-Control Commands

The remote-control commands have a syntax based on standard SCPI 1999.0, but they comply with it only to a limited extent.

Table 6-9 List of remote-control commands

Command	Parameter	Unit	Default setting	Page
* Commands				
*IDN?				6.2
*RST				6.2
*TRG				6.2
*TST?				6.2
CALibration Commands				
CALibration:DATA[?]	<calibration data set as definite length block>			6.3
CALibration:DATA:LENGth?		Bytes		6.3
CALibration:ZERO:AUTO[?]	OFF ON ONCE		OFF (fixed)	6.4
SENSe Commands				
SENSe:AVERage:COUNT[?]	1 to 65536		4	6.6
SENSe:AVERage:COUNT:AUTO[?]	OFF ON ONCE		ON	6.6
SENSe:AVERage:COUNT:AUTO:MTIME[?]	1.0 to 999.99	s	30.0	6.7
SENSe:AVERage:COUNT:AUTO:NSRatio[?]	0.0001 to 1.0	dB	0.01	6.7
SENSe:AVERage:COUNT:AUTO:RESolution[?]	1 to 4		3	6.7
SENSe:AVERage:COUNT:AUTO:TYPE[?]	RESolution NSRatio		RESolution	6.7
SENSe:AVERage:RESet				6.7
SENSe:AVERage:STATe[?]	OFF ON		ON	6.7
SENSe:AVERage:TCONtrol[?]	MOVing REPeat		REPeat	6.8
SENSe:CORRection:DCYClE[?]	0.001 to 99.999	%	1.0	6.8
SENSe:CORRection:DCYClE:STATe[?]	OFF ON		OFF	6.8
SENSe:CORRection:OFFSet[?]	-200.0 to 200.0	dB	0.0	6.9

Command	Parameter	Unit	Default setting	Page
SENSe:CORRection:OFFSet:STATe[?]	OFF ON		OFF	6.9
SENSe:CORRection:SPDevice:STATe[?]	OFF ON		OFF (can be modified by the user)	6.9
SENSe:FREQuency[?]	10.0e6 to 18.0e9 (NRP-Z51) or 40.0e9 (NRP-Z55)	Hz	50.0e6	6.9
SENSe:FUNcTION[?]	"POWer:AVG"		"POWer:AVG"	6.10
SENSe:POWer:AVG:APERture[?]	0.001 to 0.3	s	0.02	6.10
SENSe:POWer:AVG:BUFFer:SIZE[?]	1 to 1024		1	6.11
SENSe:POWer:AVG:BUFFer:STATe[?]	OFF ON		OFF	6.11
SENSe:POWer:AVG:SMOothing:STATe[?]	OFF ON		ON	6.11
SENSe:SGAMma:CORRection:STATe[?]	OFF ON		OFF	6.12
SENSe:SGAMma:MAGNitude[?]	0.0 to 1.0		0.0	6.12
SENSe:SGAMma:PHASe[?]	-360.0 to 360.0	degree	0.0	6.12
SYSTem Commands				
SYSTem:INFO? [Item]				6.13
SYSTem:INITialize				6.14
SYSTem:MINPower?		W		6.15
SYSTem:TRANsaction:BEgIn				6.14
SYSTem:TRANsaction:END				6.15
Test Commands				
TEST:SENSor?				6.16
Triggersystem Commands				
ABORt				6.17
INITiate:CONTInuous[?]	OFF ON		OFF	6.17
INITiate:IMMEDIATE				6.18
TRIGger:COUNt[?]	1 to 2×10^9		1	6.18
TRIGger:DELAy[?]	0 to 100.0	s	0.0	6.18
TRIGger:DELAy:AUTO[?]	OFF ON		OFF	6.18
TRIGger:HOLDoff[?]	0.0 to 10.0	s	0.0	6.19

Command	Parameter	Unit	Default setting	Page
TRIGger:HYSTeresis[?]	0.0 to 10.0	dB	0.0	6.19
TRIGger:IMMediate				6.19
TRIGger:LEVel[?]	x to y	W	10 × x	6.19
TRIGger:SLOPe[?]	POSitive NEGative		POSitive	6.20
TRIGger:SOURce[?]	BUS EXTernal HOLD IMMediate INTernal		IMMediate	6.20
SERVICE Commands				
SERVice:CALibration:TEMPerature	ONCE		OFF	
SERVice:CALibration:TEMPerature:DATA?		K	0.0	
SERVice:CALibration:TEST[?]			-1	
SERVice:CALibration:ZERO:NEG0?			1	
SERVice:CALibration:ZERO:POS0?			2	
SERVice:MVCorrection[?]	0 to 63		63	
SERVice:PARAmeter:RTEmp[?]	<float value>	K	0.0	
SERVice:PARAmeter:RNULL0[?]	<float value>	Ω	0.0	
SERVice:PARAmeter:RBAHN[?]	<float value>	Ω	0.0	
SERVice:PARAmeter:NREF[?]	<float value>		0.0	
SERVice:PARAmeter:ATHERM[?]	<float value>	K ⁻¹	0.0	
SERVice:PARAmeter:BTHERM[?]	<float value>	K	0.0	
SERVice:PARAmeter:CTHERM[?]	<float value>	K ⁻¹	0.0	
SERVice:PARAmeter:DTHERM[?]	<float value>	K ⁻¹	0.0	
SERVice:PARAmeter:CJUNC[?]	<float value>	F	0.0	
SERVice:RCount[?]	1 to 32767		0	
SERVice:RESult[?]	0.0 to 1.0e6	W	0.0	
SERVice:SAMPle[?]	0 to 99999999		1000	
SERVice:TDEScriptor?				
SERVice:TDEScriptor:LENGth?		Bytes		
SERVice:UNLock	1234			



ROHDE & SCHWARZ

Test and Measurement
Division

Service Instructions

Table of Contents

- 4 Firmware Update** 4.1
 - Installation of New R&S NRP-Z27/-Z37 Firmware** 4.1
 - Hardware and software requirements 4.1
 - Preparation 4.2
 - Updating the application firmware 4.3
 - Updating the boot loader 4.4

4 Firmware Update

Chapter 4 provides information on the firmware update. Descriptions enclosed with the firmware update can be filed here.

Installation of New R&S NRP-Z27/-Z37 Firmware

Use the Firmware Update program module to load new firmware. The module is part of the R&S NRP Toolkit that is supplied on a CD-ROM and enables you to update the boot loader and the application firmware.

The current firmware versions can be downloaded from the R&S homepage on the Internet, since the CD-ROM accompanying the power sensor modules contains the firmware status at the time of delivery.

Hardware and software requirements

The system requirements for a firmware update are the same as for the operation of the power sensor module on a PC (an update via the R&S NRP base unit is not possible):

- PC with free USB port.
- USB Interface Adapter R&S NRP-Z3 or R&S NRP-Z4.
- Operating system Windows™ 98, Windows™ ME, Windows™ 2000, or Windows™ XP.
- **The R&S NRP Toolkit software must already be installed on your PC.**
- One of the following files must be selected (depending on the software component to be updated):
 - <Type>_Sensor<Version Number>.nrp Application
 - Bootloader_<Version Number>.nrp, Boot loader

The files are available in the \software\firmware\sensors directory of the CD-ROM.

Preparation

- Connect the power sensor module to the PC using one of the two USB interface adapters.
- If a second R&S NRP-Z power sensor or an R&S NRP is connected to the PC, unplug these devices from the PC.
- Shortly afterwards, the PC should have identified the new USB hardware and assigned the appropriate driver from the **R&S NRP Toolkit** to the power sensor module (brief message in a small window).

If you forgot to install the R&S NRP Toolkit beforehand, Windows will try in vain to find a USB driver for the power sensor module. If this happens, the R&S NRP-Zxx is highlighted by a yellow exclamation mark in the Windows device manager. In this case, proceed as follows:



- *Abort the dialog for driver installation.*
- *Install the R&S NRP Toolkit from the CD-ROM. Then manually assign the USB driver from the toolkit to the power sensor module.*
- *Go to Control Panel – Add/Remove Hardware and start the hardware assistant to search for new components.*
- *Mark the R&S NRP-Zxx in the list of hardware components and complete the driver installation.*
- *Unplug the power sensor module and reconnect it.*

Updating the application firmware



NRP_Z21_Messkopf_01_15.nrp



The update can be started as follows:

- Either double-click the icon of the update file named <Type>_Messkopf_<Version Number>.nrp
- Or start **NRP Toolkit – Firmware Update** from the Windows Start menu.

The dialog box on the left is displayed next.

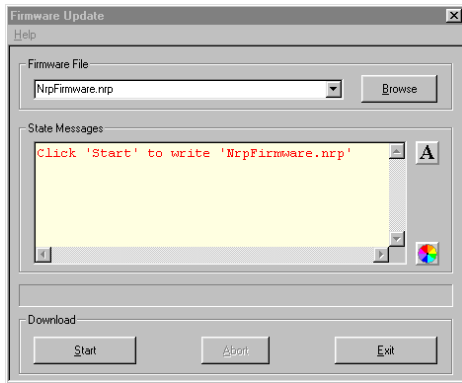

- If the update was started via the Windows Start menu, enter the file name of the application firmware in the **Firmware File** box (or search for the name by using the **Browse** button).
- Click the **Start** button to start the file transfer, which is performed automatically.

- Observe the following:

- Do not disconnect the power sensor module from the PC.
- Neither connect nor disconnect the power supply for the R&S NRP-Z3 adapter.
- Exit the Firmware Update program only after it has been completely executed.



- During the update, the State Messages box informs you of the progress. The update has been completed successfully if the message 'Device <Type Designation><Serial Number> is active' appears.
- You can then use the power sensor module for measuring.

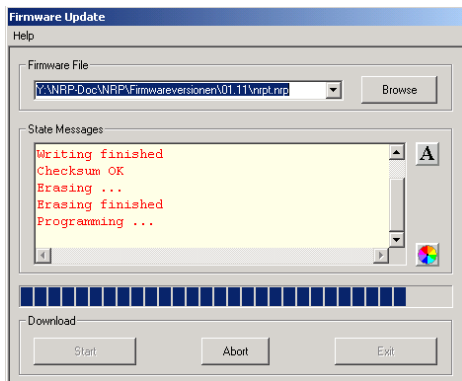

Potential problems

- Error in the compatibility and consistency checks.

In this case, the update is aborted and an error message is output.

- Unplug the power sensor module, reconnect it and start the update again.



Updating the boot loader



Bootloader_00_20.
nrp



The boot loader update is similar to the update of the application firmware (see above).

- Instead of the application, however, you must load the new boot loader named

Bootloader_<Version Number>.nrp

Strictly observe the warnings under "Updating the application firmware", since the destruction of the boot loader will generally require a repair of the power sensor module.

Potential problems

- The power sensor module cannot be accessed after the update (error message).
- Exit the Firmware Update program, unplug the power sensor module from the PC and reconnect it. The power sensor module is now ready for operation.